

Volute pumps

SJM2/SJM3

TERAL



Triple e series

50Hz

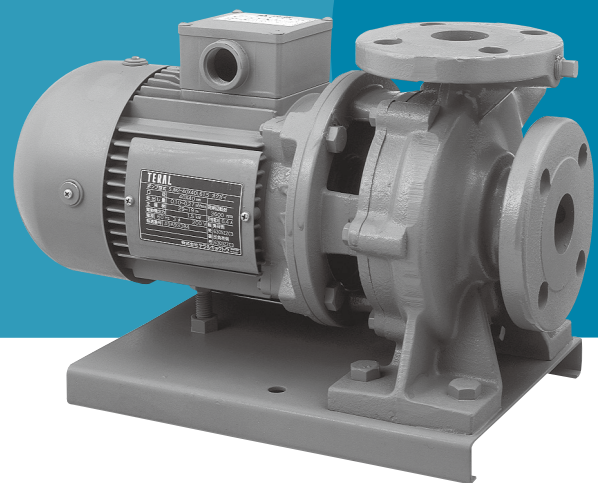

TERAL INC.

Applications

- General water supply for buildings, condominiums, etc.
- Circulation of cold/warm water
- Conveyance of industrial water
- Conveyance and distribution of tap water
- Irrigation of paddies and fields
- Water sprinkling

Features

- ① Energy-saving pump with a Top Runner efficiency (equivalent to IE3) motor. (pumps of 0.4kW or less are our high efficiency standard products.)
- ② Compact and lightweight through the adoption of 2-pole motor.
- ③ High performance covering a wide range of uses.
- ④ Easy to install, and does not require a large space.
- ⑤ Easy to perform maintenance and inspection as disassembly and reassembly can be performed without removing piping due to the B.P.O (back pull out) structure.
- ⑥ Advantageous in piping load by stable installation due to straight-up discharge.
- ⑦ Compatible mounting dimensions with conventional pumps.

Description of types

SJM2 - 32 × 32 L 5 .75 - e

- ① Model
- ② Nominal suction diameter (32mm)
- ③ Nominal discharge diameter (32mm)
- ④ Frequency (50Hz)
- ⑤ Output (0.75kW)
- ⑥ Equipped with Top Runner efficiency (equivalent to IE3) motor

Standard specifications

Pumping liquid	Liquid quality	Fresh water
	Liquid temperature	0 ~ 80°C
Total suction head (In case of 20°C)		-6m
Allowable boost pressure		See the Specification table.
Structure	Impeller	Closed
	Bearing	Sealed ball bearing
	Shaft seal	Mechanical seal (Ceramic vs Carbon)
Material	Impeller	CAC406 or SCS13 ^{*1}
	Motor shaft	SUS304
	Casing	FC200 or FCD450 ^{*1}
Motor	Efficiency	Top Runner efficiency (equivalent to IE3) (0.4kW is equivalent to IE3 efficiency)
	Starting method	Direct-on-Line start
	Type	Totally enclosed fan-cooled outdoor type
	Power source	3-phase 200V
	Synchronous rotation speed	3000min ⁻¹
Flange spec		JIS 10K thin type (special flange for nominal diameter 32mm)
Paint color		7.5BG5/1.5

*1 The material differs according to the type.

Standard accessories

Motor	1
Common base	1
Companion flange (packing, bolt, and nut included) (for nominal diameter 32mm only)	2 sets
Priming plug	1



* Please note that some of the devices in the photo may differ from actual devices in coating color, etc.

Special specifications

Structure	Shaft seal	Mechanical seal (SiC vs Carbon)
	Other	Drain (below casing) No common base
Material	Other	Completely composed of iron (Main shaft is SUS304).
Motor	Power supply	3-phase 400V
Paint		Specified color for outer surface, salt-resistant paint, heavy-duty salt-resistant paint, Sewage works agency specification

* Please note that in case of special specifications, the outline drawing, etc., may differ from the standard drawing.

Special accessories

- Foot valve
- Suction cover
- Sluice valve, check valvePacking, bolt, and nut included
- Companion flangePacking, bolt, and nut included
- * Standard accessory for nominal diameter 32mm.
- Special companion flange (for making the discharge diameter identical to the suction diameter)Bolt and nut included
- Pipe reducerSee the illustration below.
- Vibration isolator
- Pressure gauge, vacuum gauge, compound gaugeCock and pipe included
- Vibration isolation joint

Foot valve, pipe reducer, and special companion flange application table

Normal diameter mm	Foot valve nominal diameter mm	Pipe reducer	Special companion flange
32	32	—	—
40	40	—	—
50	40	—	40/50
65	50	—	50/65
80	65	80x100	65/80

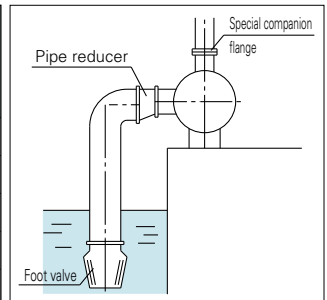

* Use the special companion flange for making the discharge diameter identical to the suction diameter.

Selection chart

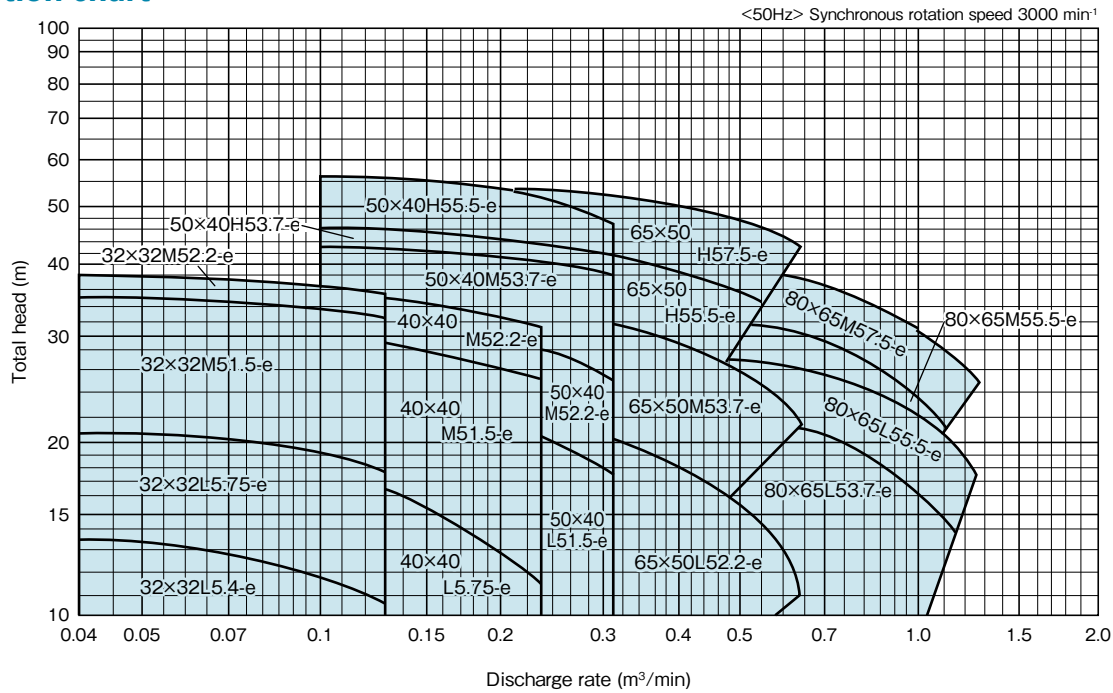

Specification table

Nominal diameter mm	Suction	Discharge	Type	Output kW	Specifications				Allowable boost pressure MPa		
					Discharge rate m³/min	Total head m	Discharge rate m³/min	Total head m		Discharge rate m³/min	Total head m
32	32		SJM2-32x32L5.4-e	0.4	0.04	13.5	0.09	12	0.13	10.5	0.59
			SJM2-32x32L5.75-e	0.75	0.04	20.5	0.09	19.5	0.13	18	0.59
			SJM2-32x32M51.5-e	1.5	0.04	35	0.09	34	0.13	33	0.59
			SJM2-32x32M52.2-e	2.2	0.04	38	0.09	36.5	0.13	35.5	0.57
40	40		SJM2-40x40L5.75-e	0.75	0.09	18	0.15	15.5	0.23	11.5	0.59
			SJM2-40x40M51.5-e	1.5	0.09	30	0.15	28	0.23	25	0.59
			SJM2-40x40M52.2-e	2.2	0.09	36.5	0.15	34	0.23	31	0.57
50	40		SJM2-50x40L51.5-e	1.5	0.10	22.5	0.21	21	0.31	17.5	0.59
			SJM2-50x40M52.2-e	2.2	0.10	32	0.21	29	0.31	25	0.59
			SJM2-50x40M53.7-e	3.7	0.10	43	0.21	41	0.31	38	0.52
			SJM2-50x40H53.7-e	3.7	0.10	46.5	0.21	44.5	0.31	41.5	0.49
			SJM3-50x40H55.5-e	5.5	0.10	56	0.21	53	0.31	47	0.44
65	50		SJM3-65x50L52.2-e	2.2	0.21	22	0.42	18	0.63	11	0.59
			SJM3-65x50M53.7-e	3.7	0.21	33	0.42	28.5	0.63	21.5	0.59
			SJM3-65x50H55.5-e	5.5	0.21	42.5	0.42	38.8	0.55	34	0.56
			SJM3-65x50H57.5-e	7.5	0.21	53.5	0.42	50.5	0.63	43	0.46
80	65		SJM3-80x65L53.7-e	3.7	0.42	22.2	0.84	18.3	1.15	14	0.59
			SJM3-80x65L55.5-e	5.5	0.42	27.5	0.84	23.8	1.25	17.8	0.59
			SJM3-80x65M55.5-e	5.5	0.42	31.5	0.84	26.5	1.11	20.6	0.59
			SJM3-80x65M57.5-e	7.5	0.42	39	0.84	33.5	1.25	24.5	0.59

Motor specification table

Classification		Output kW	Rating			Starting			Thermal class	Bearing **1	
Phase	Type		Voltage V	Current A	Rotation speed min⁻¹	Torque %	Current A	Method		Load side (D.S)	Anti-load side (O.S)
3-phase	Totally enclosed fan-cooled outdoor type	0.4	200	1.7	2870	379	14.2	Direct-on-Line	F	6204ZC3E	6203ZC3E
		0.75	200	3.2	2880	331	26.8	Direct-on-Line	F	6205ZC3E	6204ZC3E
		1.5	200	5.9	2895	312	39	Direct-on-Line	B	6306ZC3E	6305ZC3E
		2.2	200	8.4	2880	313	61.7	Direct-on-Line	B	6306ZC3E	6205ZC3E
		3.7	200	14.9	2930	319	143	Direct-on-Line	B	6307ZC3E	6306ZC3E
		5.5	200	22	2930	235	182	Direct-on-Line	B	6308ZC3E	6306ZC3E
		7.5	200	28.4	2920	242	234	Direct-on-Line	B	6308ZC3E	6306ZC3E

*1 Urea grease is used for bearings.

Component parts list

Type	Mechanical seal	O-ring (for casing)	O-ring (for priming)
SJM2-32x32L5.4-e	H-16	G140	P22
SJM2-32x32L5.75-e	H-16	G140	P22
SJM2-32x32M51.5-e	H-20H	K184	P22
SJM2-32x32M52.2-e	H-20H	K184	P22
SJM2-40x40L5.75-e	H-16	G140	P22
SJM2-40x40M51.5-e	H-20H	K184	P22
SJM2-40x40M52.2-e	H-20H	K184	P22
SJM2-50x40L51.5-e	H-20H	G140	P22
SJM2-50x40M52.2-e	H-20H	K184	P22
SJM2-50x40M53.7-e	H-20H	K184	P22

Type	Mechanical seal	O-ring (for casing)	O-ring (for priming)
SJM2-50x40H53.7-e	H-20H	K223	P22
SJM3-50x40H55.5-e	H-25H-1	K223	P22
SJM3-65x50L52.2-e	H-20H	G140	P22
SJM3-65x50M53.7-e	H-20H	K184	P22
SJM3-65x50H55.5-e	H-25H-1	K223	P22
SJM3-65x50H57.5-e	H-25H-1	K223	P22
SJM3-80x65L53.7-e	H-20H	K160	P22
SJM3-80x65L55.5-e	H-25H-1	K160	P22
SJM3-80x65M55.5-e	H-25H-1	K184	P22
SJM3-80x65M57.5-e	H-25H-1	K184	P22

Assembly drawing

●SJM2-e

Fig. 1

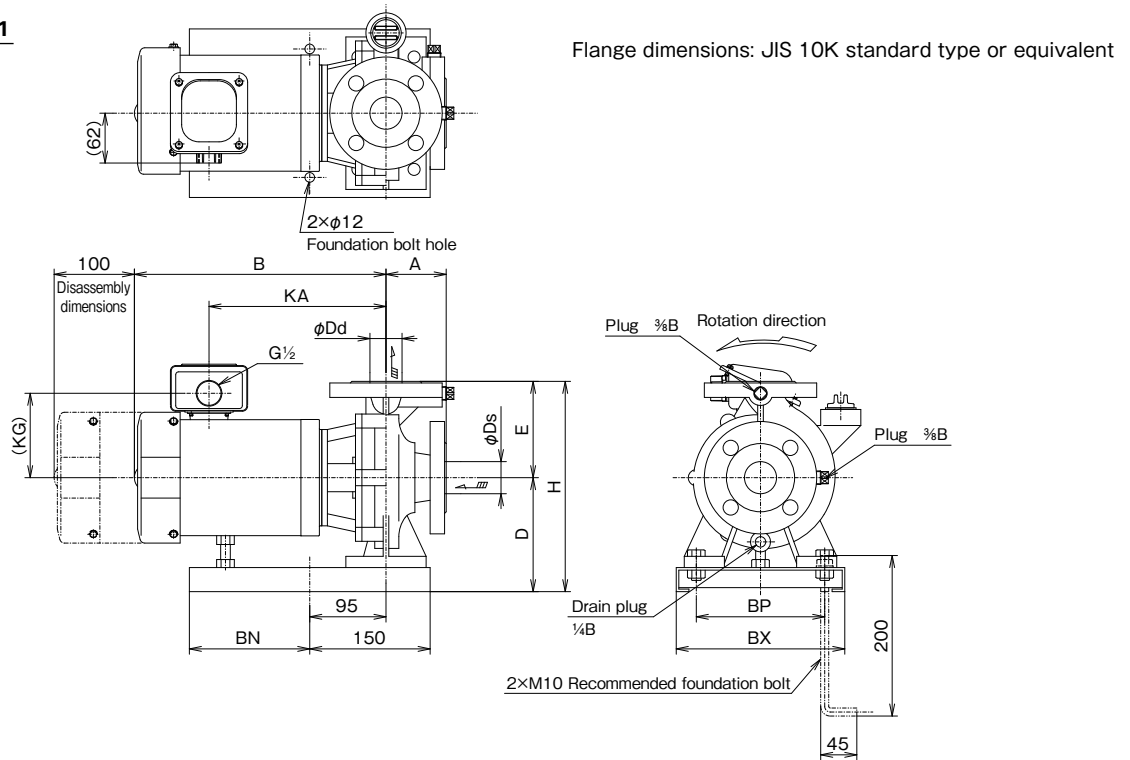
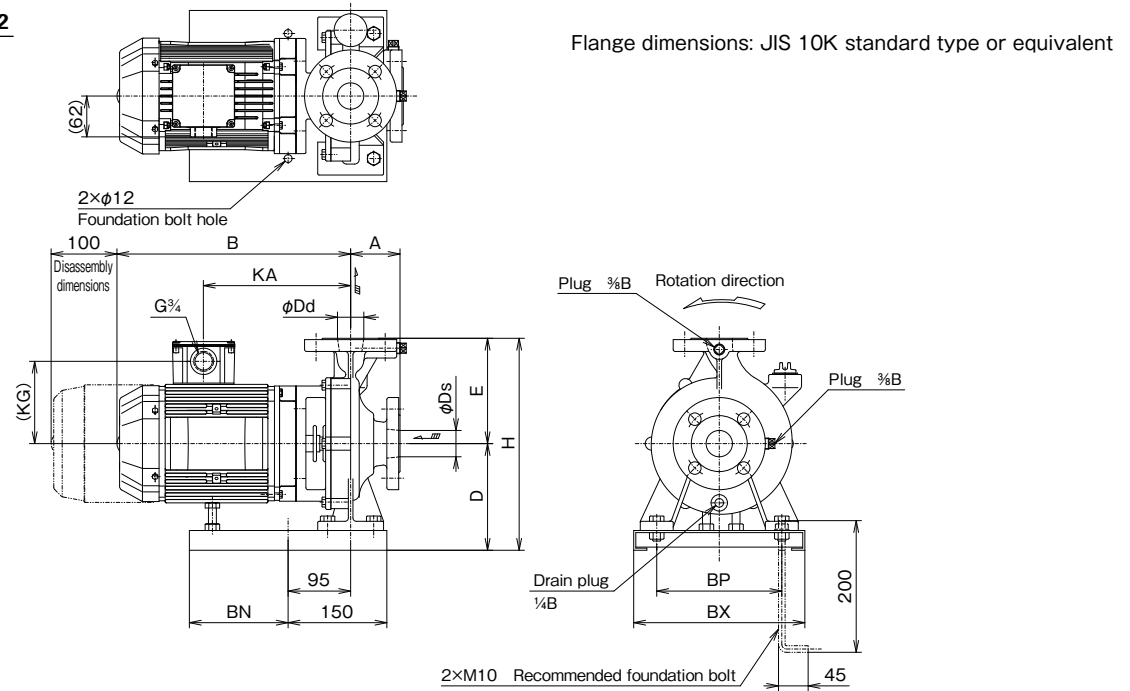

Fig. 2



Dimensions

(Unit: mm)

Nominal diameter		Type	Output kW	Fig	Pump/Motor							Common base			Approx. mass kg
Suction Ds	Discharge Dd				A	B	D	E	H	KA	KG	BN	BP	BX	
32	32	SJM2-32×32L5.4-e	0.4	1	75	305	142	120	262	227	103	150	160	210	29
		SJM2-32×32L5.75-e	0.75	1	75	314	142	120	262	221	111	150	160	210	31
		SJM2-32×32M51.5-e	1.5	2	75	350	162	160	322	219	123	185	190	260	37
		SJM2-32×32M52.2-e	2.2	2	75	350	162	160	322	219	123	185	190	260	38
40	40	SJM2-40×40L5.75-e	0.75	1	75	314	142	120	262	221	111	150	160	210	31
		SJM2-40×40M51.5-e	1.5	2	75	350	162	160	322	219	123	185	190	260	37
		SJM2-40×40M52.2-e	2.2	2	75	350	162	160	322	219	123	185	190	260	39
50	40	SJM2-50×40L51.5-e	1.5	2	80	355	142	140	282	224	123	150	160	210	37
		SJM2-50×40M52.2-e	2.2	2	80	350	162	160	322	219	123	185	190	260	45
		SJM2-50×40M53.7-e	3.7	2	80	393	162	160	322	255	147	185	190	260	63
		SJM2-50×40H53.7-e	3.7	2	80	398	190	180	370	260	147	185	190	260	66

Assembly drawing

● SJM3-e (3.7kW or less)

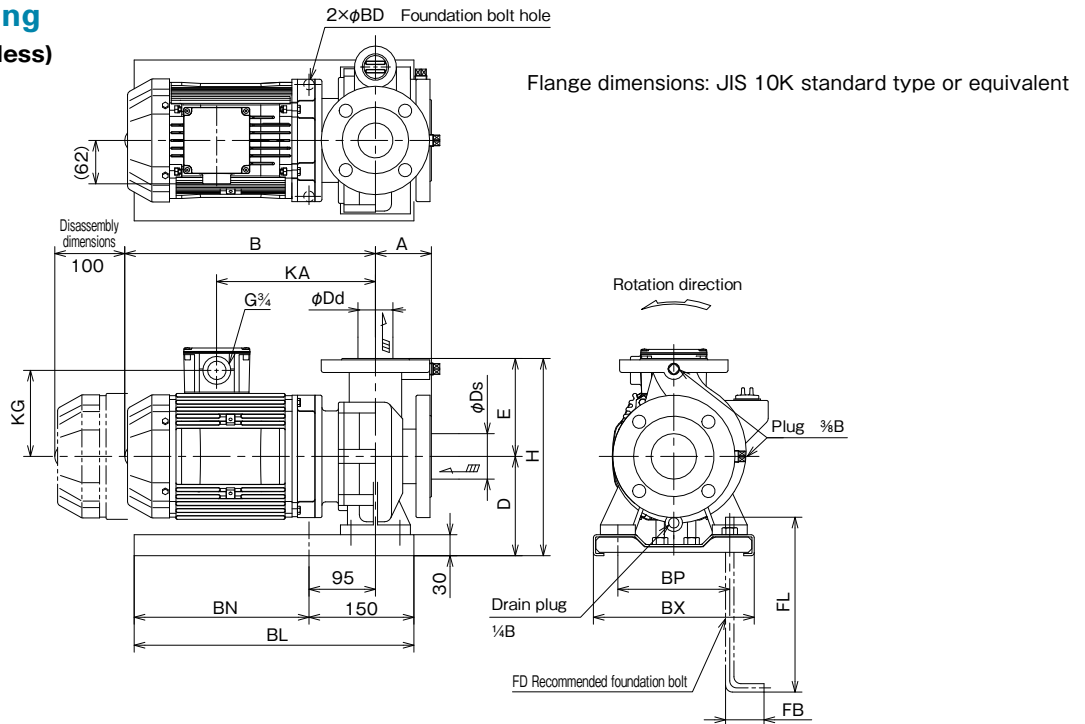

Dimensions

(Unit: mm)

Nominal diameter		Type	Output kW	Pump/Motor						Common base					Foundation bolt			Approx. mass kg	
Suction D _s	Discharge D _d			A	B	D	E	H	KA	KG	BD	BL	BN	BP	BX	FB	FD		FL
65	50	SJM3-65×50L52.2-e	2.2	80	359	142	140	282	228	123	15	400	250	160	230	55	4×M12	250	32
		SJM3-65×50M53.7-e	3.7	80	402	162	160	322	264	147	12	335	185	190	260	45	2×M10	200	64
80	65	SJM3-80×65L53.7-e	3.7	100	402	162	160	322	264	147	12	335	185	190	260	45	2×M10	200	61

Assembly drawing

● SJM3-e (5.5kW or more)

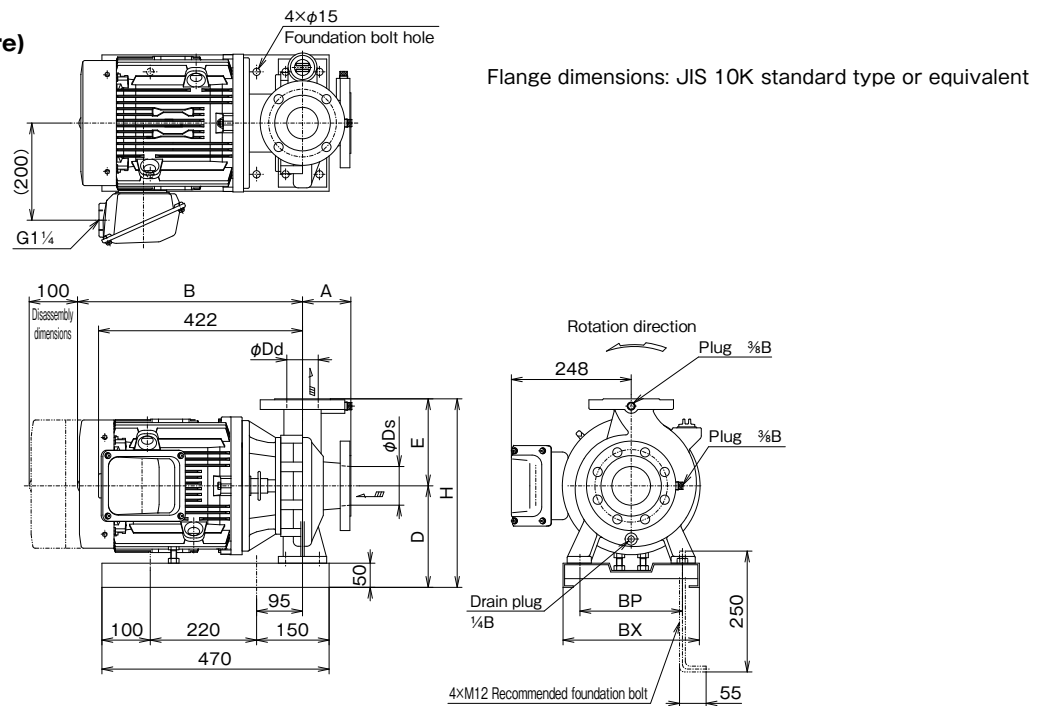

Dimensions

(Unit: mm)

Nominal diameter		Type	Output kW	Pump/Motor					Common base		Approx. mass kg
Suction D _s	Discharge D _d			A	B	D	E	H	BP	BX	
50	40	SJM3-50×40H55.5-e	5.5	80	466	210	180	390	190	260	79
65	50	SJM3-65×50H55.5-e	5.5	100	466	210	180	390	212	282	82
		SJM3-65×50H57.5-e	7.5	100	466	210	180	390	212	282	87
		SJM3-80×65L55.5-e	5.5	100	466	207	160	367	190	260	78
80	65	SJM3-80×65M55.5-e	5.5	100	466	210	180	390	212	282	80
		SJM3-80×65M57.5-e	7.5	100	466	210	180	390	212	282	85

Example of sectional drawing

●SJM2-e

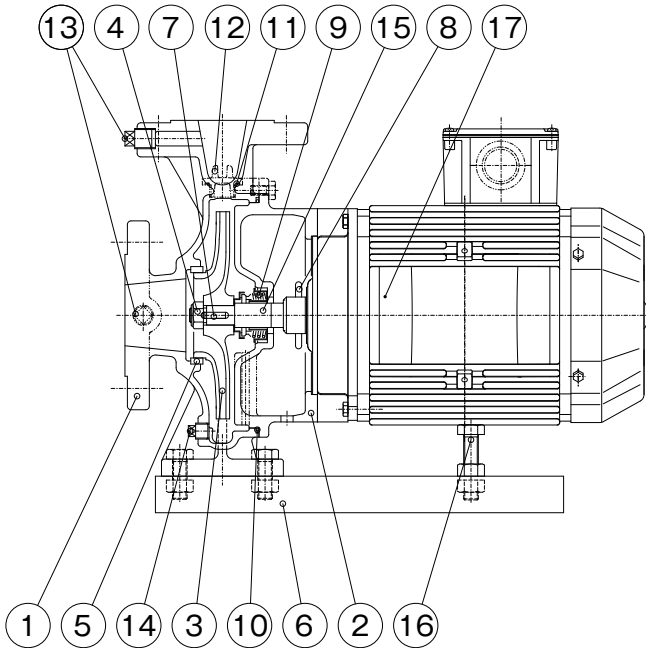

Parts list

No.	Part name	Qty	Material
1	Casing	1	FC200
2	Frame	1	FC200
3	Impeller	1	CAC406
4	Impeller nut	1	SUS304
5	Liner ring	1	CAC406
6	Common base	1	SPHC
7	Key	1	SUS304
8	Deflector	1	CR
9	Mechanical seal	1	(Ceramic vs Carbon)
10	O-ring	1	NBR
11	O-ring	1	NBR
12	Priming plug	1	CAC202
13	Plug	1	SWCH
14	Plug	1	SWCH
15	Motor shaft *1	1	Liquid contact part: SUS304
16	Support bolt	1 or 2 *2	SS400
17	Motor	1	—

*1 The indicated materials are equivalent products.

*2 0.75kW or less: 1 1.5kW or more: 2

●SJM3-e

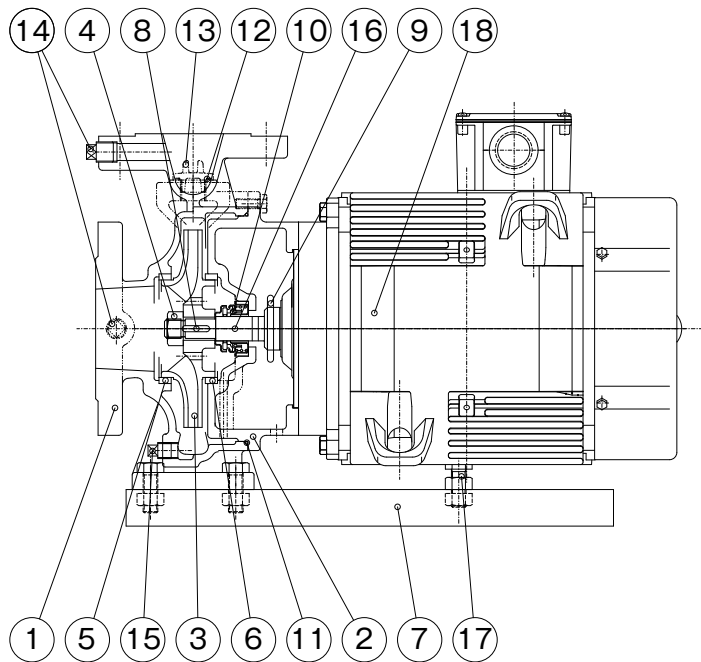

No.	Part name	Qty	Material
1	Casing	1	FC200 or FCD450*1
2	Frame	1	FC200
3	Impeller	1	SCS13
4	Impeller nut	1	SUS304
5	Liner ring	1	CAC406
6	Liner ring	1	CAC406
7	Common base	1	SPHC
8	Key	1	SUS304
9	Deflector	1	CR
10	Mechanical seal	1	(Ceramic vs Carbon)
11	O-ring	1	NBR
12	O-ring	1	NBR
13	Priming plug	1	CAC202
14	Plug	2	SWCH
15	Plug	1	SWCH
16	Motor shaft *1	1	Liquid contact part: SUS304
17	Support bolt	2	SS400
18	Motor	1	—

*1 The material differs according to the type.

*2 The indicated materials are equivalent products.



TERAL INC.

Head Office 230, Moriwake, Miyuki-cyo, Fukuyama-city, Hiroshima, 720-0003, Japan
Tel.+81-84-955-1111 Fax.+81-84-955-5777
www.teral.net

Teral Asia Limited

Room 1001,10/F, Olympia Plaza, 255 King's Road, North Point, Hong Kong
Tel.+852-2571-0935 Fax.+852-2571-0619

TERAL THAI CO.,LTD.

150 Moo 16 Udomsorasayuth Rd., T.Bangkrasan, A.Bangpa-In, Ayutthaya 13160 Thailand
Tel.+66-3535-2148-9 Fax.+66-3535-2150

TERAL TRADING & SERVICE CO.,LTD.

150 Moo 16 Udomsorasayuth Rd., T.Bangkrasan, A.Bangpa-In, Ayutthaya 13160 Thailand
Tel.+66-3535-2145-7 Fax.+66-3535-8549

Teral Malaysia Sdn.Bhd.

10, Jalan SS13/6A, Subang Jaya Industrial Estate, 47500, Subang Jaya, Selangor D.E, Malaysia
Tel.+60-3-5611 5775 Fax.+60-3-5612 5775

PT.Teral Indonesia Pumps and Fans

Komplek Pergudangan Taman Tekno Blok M No.26.Jl.BSD Sektor XI, Kelurahan Setu,
Kecamatan Setu, Kota Tangerang Selatan, Provinsi Banten.15314.
Tel.+62-21-29665778 Fax.+62-21-75673913

Teral Vietnam Limited Liability Company

9th Floor, LADECO Building, No. 266 Doi Can Street, Lieu Giai Ward, Ba Dinh District, Hanoi City, Vietnam
Tel.+84-24-393-52-790 Fax.+84-24-393-52-289

Teral General Machine (Shanghai) Co.,Ltd.

No.285, Yuan Qu Road(N), Bei Qiao, Min Hang District, Shanghai 201109, China
Tel.+86-21-6490-9128 Fax.+86-21-6490-9126

Teral-Aerotech Fans Private Ltd.

Plot No.188-189, Ecotech Extension-1, Surajpur Kasna Road, Greater Noida-201306, Uttar Pradesh, India
Tel.+91-9810162210, +91-9310162210

Teral Middle East F.Z.C.

1806-002, 18th floor, BB1, Mazaya Business Avenue, JLT, Dubai, UAE. PO Box 414781
Tel.+971-4369 9039

Teral Pumps & Fans North America Ltd.

Suite # 197, 800-15355 24 Ave Surrey, B.C., CANADA V4A 2H9
Tel.+1-604-839-1008

Teral Philippines Inc.

Roof Deck 3, Vernida 1 Building, 120 Amorsolo St., Legaspi Village, Makati City
Tel.+63 2 7717-9314

Please note that product specifications are subject to change for improvement without prior notice.

2019 , 08