

Line pumps

LP/LPE

TERAL



Triple e series

50Hz



Applications

- Circulation of cold/warm water
- Cooling and air-conditioning systems
- General water supply
- Pressurization of tap water
- Pressurization of industrial water
- Other uses

Features

- ①Energy-saving pump with a Top Runner efficiency (equivalent to IE3) motor.
(Excluding pumps of single-phase and 3-phase 0.15kW or less. Pumps of 3-phase 0.25 to 0.4kW are our high efficiency standard products.)
- ②Installable in the middle of piping, and does not require large installation space.
- ③Compact, lightweight, and easy-to-handle because disassembly and inspection can be performed without removing piping.
- ④No water leakage through the adoption of a mechanical seal.
- ⑤Usable for high-temperature and high-pressure water, and suitable as a circulating pump of cold/warm water.
- ⑥Easy maintenance (Nominal diameter : 125~200mm)
When replacing the mechanical seal, no need to disassemble the pump or to remove the motor. LPE model achieves less work time than the conventional type.
- ⑦Capable of high back pressure spec (Nominal diameter : 125~200mm)
Allowable boost pressure up to 1.6MPa supported by simple and high-rigidity structure based on rational design.
- ⑧Space-saving (Nominal diameter : 125~200mm)
Installable in places where horizontal pumps would be hard to install. The installation area is approx. 50% compared with our SJ4-e and SKJ-e models of horizontal pumps having comparable output.
- ⑨High efficiency of pump (nominal diameter: 125~200mm)
Increase in efficiency by 5 to 10% from conventional pumps by optimum design based on three-dimensional flow analysis and structural analysis.
- ⑩Compatible mounting dimension with conventional pumps.
(Some LPE models require special accessory.)



* Please note that some of the devices in the photo may differ from actual devices in coating color, etc.

Description of types

LP 32 A 5 .75 - e

① ② ③ ④ ⑤ ⑥ ⑦

- ①Model
- ②Bore diameter
- ③Type
- ④Frequency 5 : 50Hz
6 : 60Hz
- ⑤Output
- ⑥Phase S : single-phase
None: 3-phase
- ⑦Motor efficiency
None: Standard efficiency (equivalent to IE1)
e: Top Runner efficiency (equivalent to IE3)

LPE 150 K - 5 15 - e

① ② ③ ④ ⑤ ⑥

- ①Model
- ②Bore diameter
- ③Type
- ④Frequency 5 : 50Hz
6 : 60Hz
- ⑤Output
- ⑥Motor efficiency Top Runner efficiency (equivalent to IE3)

Standard specifications

●Nominal diameter: 25~100mm

Pumping liquid	Liquid quality	Fresh water
	Liquid temperature	0~90°C...(0.15kW or less) 0~80°C...(0.25kW or more) *1
Total suction head (In case of 20°C)		-6m *2 For use with the total head 10m or less, take 60% or less of the total head.
Allowable positive pressure		See the specification table.
Structure	Impeller	Closed
	Shaft seal	Mechanical seal
	Bearing	Sealed ball bearing
Material *3	Impeller	CAC406 *4
	Shaft	SUS304 (3-phase). See the table below.
		SUS304 (single-phase, 0.25kW, 0.4kW)
	Casing	FC200
Motor	Efficiency	Standard efficiency (equivalent to IE1): Single-phase, 3-phase 0.15kW or less Top Runner efficiency (equivalent to IE3): 3-phase 0.25kW or more
	Type	Totally enclosed self-cooled outdoor type: Single-phase 0.08kW or less, 3-phase 0.08kW Drip-proof protected type: Single-phase 0.15kW or more, 3-phase 0.15kW Totally enclosed fan-cooled outdoor type: 3-phase 0.25kW or more
		Power source
	Synchronous rotation speed	3000min ⁻¹
Flange spec		Nominal diameter 25mm : special companion flange Nominal diameter 32mm or more: JIS 10K thin type
Paint		Acrylic alkyd resin paint (Munsell 7.5BG5/1.5)

*1 For more than 80°C, contact us separately.
*2 Negative suction is not available for LP25A 0.08kW or less, single/3-phase.
*3 Refer to the supplemental table shown below for LP25A.
*4 The impeller material for LP32A is PPS (polyphenylene sulfide resin).

Supplementary table

Phase and voltage	Output kW	Impeller material	Shaft material	Casing material (O-ring material)
Single-phase, 100V	0.04,0.05,0.08	PPS resin	SUS430	FC180(EPDM)
	0.15	NORYL resin	SUS303	FC150(NBR)
	0.25	SUS304	SUS304	FC200(NBR)
3-phase, 200V	0.08	PPS resin	SUS430	FC180(EPDM)
	0.25	SUS304	SUS304	FC200(NBR)

Standard accessories

●Nominal diameter: 25mm

Special companion flange (bolt, nut and packing included).....2 sets

Special specifications

Structure	Shaft seal	Mechanical seal (SiC vs Carbon) (25~100mm) Mechanical seal (SiC vs SiC) (125~200mm)
	Other	Drain (below casing) (25~100mm) High back pressure (Allowable boost pressure: 1.6MPa) (125~200mm)
Material	Impeller	SUS304 / SCS13 (25~100mm) *1
Motor	Power source	3-phase 400V class
Paint		Specified color for outer surface, salt-resistant paint, heavy-duty salt-resistant paint, Sewage works agency specification

*1 Not available for LP25A, LP40A and LP50A.

●Nominal diameter: 125~200mm

Pumping liquid	Liquid quality	Fresh water (brine supported as custom-made) *1
	Liquid temperature	0 ~ 80°C
Total suction head (In case of 20°C)		Determined by liquid temperature, NPSHR and piping loss on the suction side *2
Allowable positive pressure		See the Specification table.
Structure	Impeller	Closed
	Shaft seal	Mechanical seal (SiC vs Carbon)
	Bearing	Sealed ball bearing
Material	Impeller	SCS13
	Motor shaft	SUS420J2
	Casing	FCD450
Motor	Type	Totally enclosed fan-cooled outdoor type
	Power source	3-phase, 200V (7.5kW or less) 3-phase, 200/400V (11kW or more)
	Synchronous rotation speed	1500min ⁻¹
Flange spec		JIS 10K standard type
Paint*4	Pump part	Acrylic alkyd resin, blue
	Motor	Polyurethane black (RAL-9005/equivalent to Munsell N1)

*1 Contact us for use of brine because it depends on liquid quality.
*2 Confirm that the following calculation equation is met.
Suction total head (suction height + suction piping loss) ≤ Liquid level atmospheric pressure (10.3m) – NPSHR (Net Positive Suction Head Required) *3 × Margin ratio (1.3)
*3 For NPSHR, refer to the graph of Net Positive Suction Head Required.
*4 Paint color change is possible only in the pump section.

●Nominal diameter: 125~200mm

Packing for flange and coupling cover1 set

Special accessories

Companion flange.....Packings, bolts, and nuts included (Nominal diameter: 25mm), sluice valve, check valve, pressure gauge, vacuum gauge, compound gauge, foot valve, welded flange, vibration isolator, spacer (bore diameter 125~200mm: for adjustment of discharge height)

Selection chart

●Nominal diameter: 25~100mm

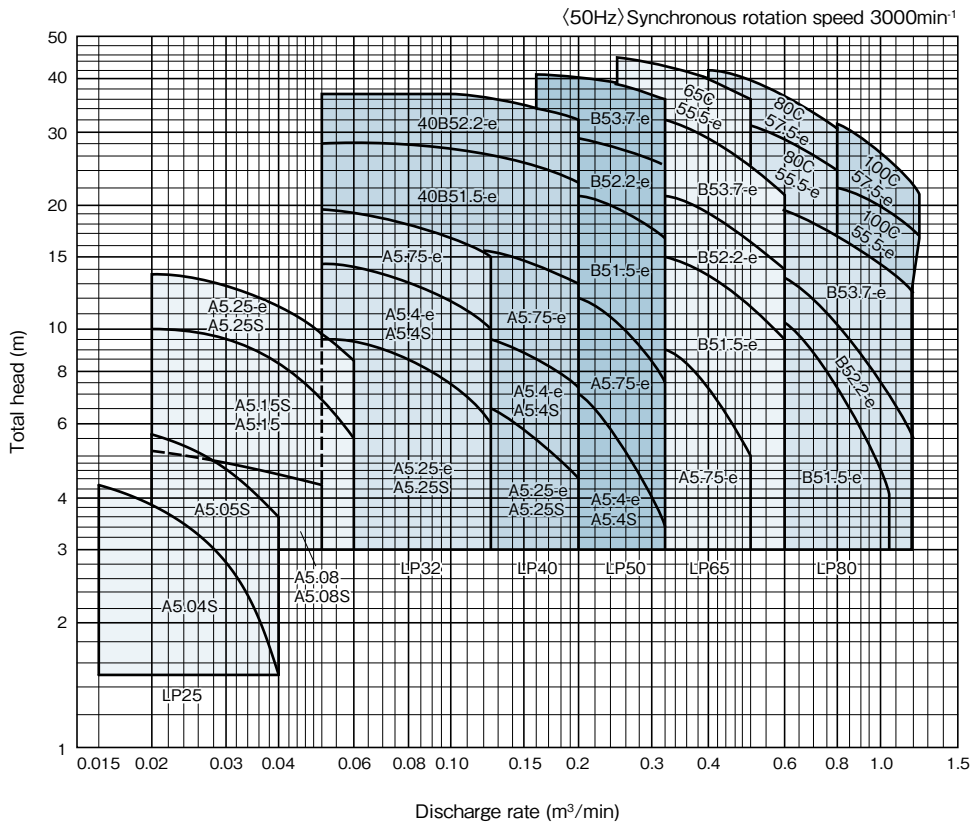

●Nominal diameter: 125~200mm

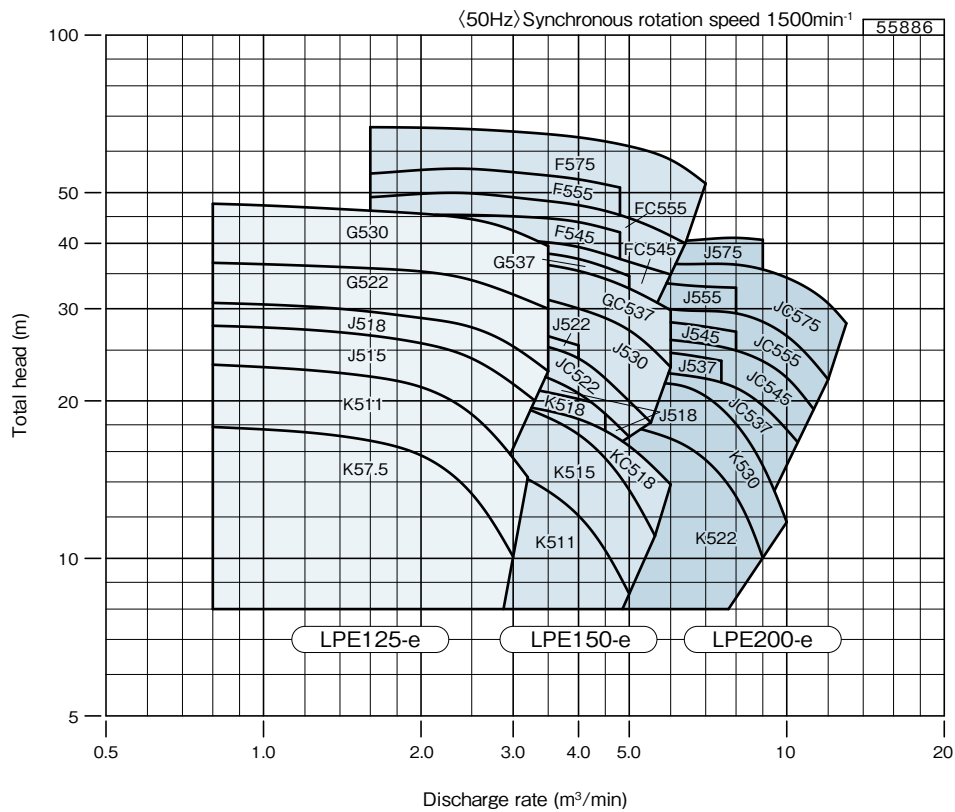

■ Net Positive Suction Head Required (NPSHR): Bore diameter 125~200mm

● Nominal diameter: 125mm

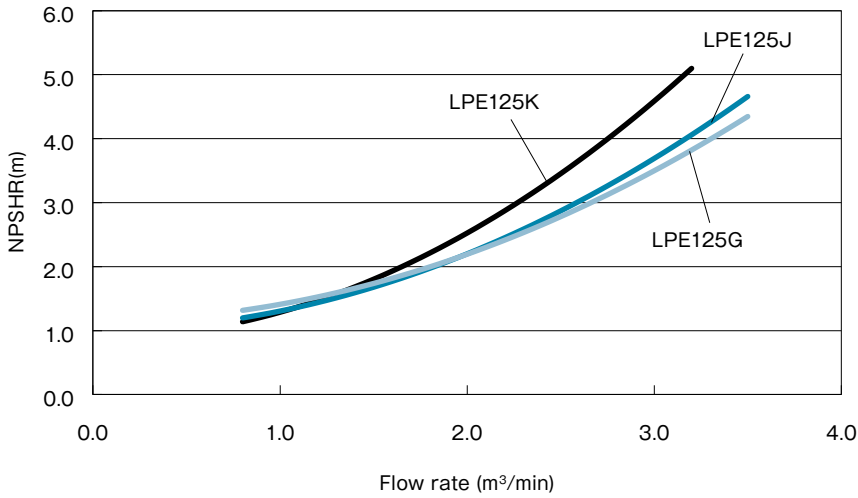

● Nominal diameter: 150mm

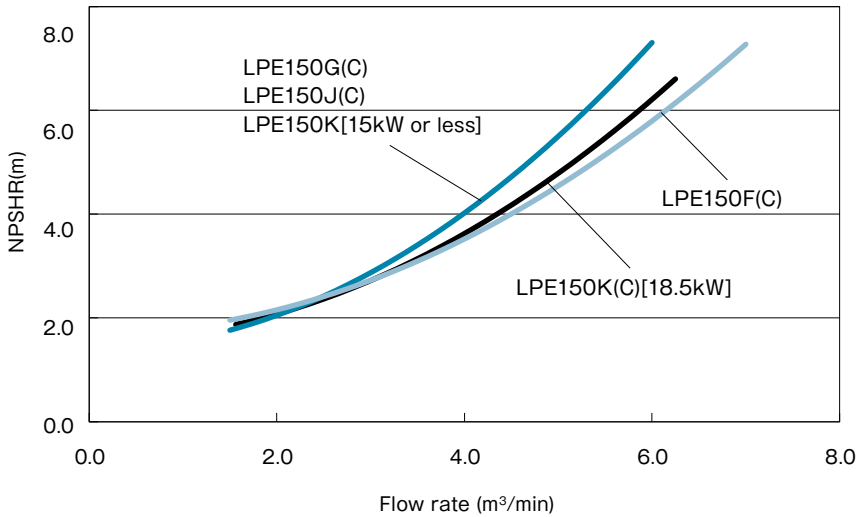

● Nominal diameter: 200mm

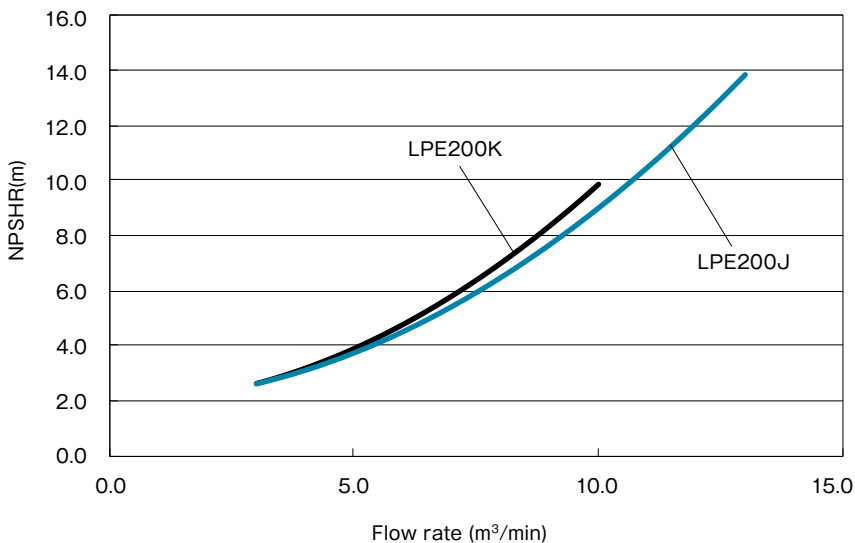

Specification table

Phase	Nominal diameter mm	Type	Output kW	Specifications						Allowable positive pressure MPa	
				Discharge rate m ³ /min	Total head m	Discharge rate m ³ /min	Total head m	Discharge rate m ³ /min	Total head m		
Single-phase	25	LP25A5.04S	0.04	0.015	4.3	0.03	2.8	0.04	1.5	0.1	
		LP25A5.05S	0.05	0.02	5.7	0.03	4.7	0.04	3.6	0.1	
		LP25A5.08S	0.08	0.02	5.2	0.035	4.7	0.05	4.3	0.1	
		LP25A5.15S	0.15	0.025	9.5	0.05	7	0.07	4.5	0.2	
	32	LP25A5.25S	0.25	0.02	13.5	0.04	11.5	0.06	8.5	0.2	
		LP32A5.4S	0.4	0.05	14.2	0.09	12.5	0.125	10.5	0.39	
	40	LP40A5.25S	0.25	0.10	7	0.16	5.5	0.20	4.5	0.39	
		LP40A5.4S	0.4	0.10	10	0.16	8.5	0.20	7.5	0.39	
	50	LP50A5.4S	0.4	0.16	8	0.25	5.5	0.32	3.5	0.39	
	3-Phase	25	LP25A5.08	0.08	0.02	5.2	0.035	4.7	0.05	4.3	0.1
			LP25A5.15	0.15	0.025	9.5	0.05	7	0.07	4.5	0.2
			LP25A5.25-e	0.25	0.02	13.5	0.04	11.5	0.06	8.5	0.2
32		LP32A5.25-e	0.25	0.05	9.5	0.09	8	0.125	6	0.39	
		LP32A5.4-e	0.4	0.05	14.2	0.09	12.5	0.125	10.5	0.39	
		LP32A5.75-e	0.75	0.05	19	0.09	17	0.125	15	0.39	
40		LP40A5.25-e	0.25	0.10	7	0.16	5.5	0.20	4.5	0.39	
		LP40A5.4-e	0.4	0.10	10	0.16	8.5	0.20	7.5	0.39	
		LP40A5.75-e	0.75	0.10	16	0.16	14	0.20	13	0.39	
		LP40B51.5-e	1.5	0.05	28	0.10	27	0.20	23	0.59	
50		LP40B52.2-e	2.2	0.05	37	0.10	36.5	0.20	32.5	0.59	
		LP50A5.4-e	0.4	0.16	8	0.25	5.5	0.32	3.5	0.39	
		LP50A5.75-e	0.75	0.16	13	0.25	10.5	0.32	7.5	0.39	
		LP50B51.5-e	1.5	0.16	21	0.25	19.5	0.32	17	0.59	
		LP50B52.2-e	2.2	0.16	29.5	0.25	27	0.32	24.5	0.59	
		LP50B53.7-e	3.7	0.16	41	0.25	39	0.32	36.5	0.54	
65		LP65A5.75-e	0.75	0.25	10	0.40	7.5	0.50	5	0.39	
		LP65B51.5-e	1.5	0.25	15.5	0.40	13.5	0.60	9.5	0.59	
		LP65B52.2-e	2.2	0.25	22	0.40	19	0.60	14	0.59	
		LP65B53.7-e	3.7	0.25	32	0.40	28.5	0.60	21.5	0.59	
80		LP65C55.5-e	5.5	0.25	45	0.40	40	0.50	36	0.39	
		LP80B51.5-e	1.5	0.40	12.5	0.60	10.5	1.05	4	0.59	
		LP80B52.2-e	2.2	0.40	15	0.60	13.5	1.20	5.5	0.59	
		LP80B53.7-e	3.7	0.40	21.5	0.60	19.5	1.20	12.5	0.59	
100		LP80C55.5-e	5.5	0.40	32.5	0.60	29	0.80	24	0.39	
		LP80C57.5-e	7.5	0.40	42	0.60	37	0.80	30	0.39	
		LP100C55.5-e	5.5	0.63	23	1.0	20	1.25	17	0.39	
		LP100C57.5-e	7.5	0.63	33	1.0	27	1.25	21.5	0.39	

Nominal diameter mm	Type	Output kW	Specifications						Allowable positive pressure MPa
			Discharge rate m ³ /min	Total head m	Discharge rate m ³ /min	Total head m	Discharge rate m ³ /min	Total head m	
125	LPE125K-57.5-e	7.5	0.8	17.8	2.0	15.7	3.0	10.1	1.18
	LPE125K-511-e	11	0.8	23.5	2.0	21.3	3.2	14.3	1.13
	LPE125J-515-e	15	0.8	27.8	2.0	25.8	3.3	20.0	1.09
	LPE125J-518-e	18.5	0.8	30.8	2.0	28.8	3.5	22.8	1.06
	LPE125G-522-e	22	0.8	36.7	2.0	35.3	3.5	30.0	1.00
	LPE125G-530-e	30	0.8	47.6	2.0	45.6	3.5	39.5	0.89
150	LPE150K-511-e	11	1.6	17.3	3.2	10.2	5.0	8.6	1.19
	LPE150K-515-e	15	1.6	22.6	3.2	19.3	5.6	11.0	1.14
	LPE150K-518-e	18.5	1.6	23.1	3.2	21.1	4.5	19.6	1.14
	LPE150KC-518-e	18.5	1.6	21.4	3.2	19.5	6.0	13.8	1.16
	LPE150J-518-e	18.5	1.6	26.1	3.2	22.9	5.0	17.1	1.11
	LPE150J-522-e	22	1.6	30.7	3.2	27.3	4.0	25.5	1.06
	LPE150JC-522-e	22	1.6	29.3	3.2	26.0	5.5	18.2	1.08
	LPE150J-530-e	30	1.6	33.8	3.2	30.0	6.0	23.2	1.02
	LPE150G-537-e	37	1.6	40.1	3.2	38.6	5.0	34.6	0.98
	LPE150GC-537-e	37	1.6	38.2	3.2	36.8	6.0	29.8	0.99
	LPE150F-545-e	45	1.6	45.2	3.2	44.9	4.8	42.0	0.94
	LPE150FC-545-e	45	1.6	40.9	4.0	39.4	6.0	34.9	0.98
	LPE150F-555-e	55	1.6	54.4	3.2	54.4	4.8	51.1	0.84
	LPE150FC-555-e	55	1.6	49.0	4.0	47.3	6.4	40.0	0.89
LPE150F-575-e	75	1.6	66.7	4.0	63.8	7.0	52.0	0.72	
200	LPE200K-522-e	22	3.2	20.8	6.4	16.4	9.0	10.0	1.16
	LPE200K-530-e	30	3.2	23.6	6.4	21.3	10.0	11.7	1.13
	LPE200J-537-e	37	3.2	25.8	6.4	24.5	7.5	23.9	1.11
	LPE200JC-537-e	37	3.2	23.6	6.4	22.4	10.5	16.7	1.14
	LPE200J-545-e	45	3.2	29.3	6.4	28.1	8.0	27.1	1.08
	LPE200JC-545-e	45	3.2	27.2	6.4	26.0	11.0	19.9	1.10
	LPE200J-555-e	55	3.2	34.5	6.4	33.3	8.0	32.9	1.03
	LPE200JC-555-e	55	3.2	31.0	8.0	29.4	12.0	22.0	1.06
	LPE200J-575-e	75	3.2	40.9	6.4	40.5	9.0	40.6	0.96
	LPE200JC-575-e	75	3.2	38.0	8.0	37.4	13.0	25.3	0.99

* The allowable positive pressure for high back pressure is 1.6MPa.

Motor specification table

●Nominal diameter: 25~100mm

Classification		Output kW	Rating			Starting			Thermal class	Bearing	
Phase	Type		Voltage V	Current A	Rotation speed min ⁻¹	Torque %	Current A	Method		Load side (D.S)	Anti-load side (O.S)
Single phase	Totally enclosed self-cooling outdoor type	0.04	100	1.0	2870	98.1	3.6	Capacitor	F	6201UUC3	6201UUC3
		0.05	100	1.3	2790	77.2	3.6	Capacitor	F	6201UUC3	6201UUC3
		0.08	100	1.9	2865	81.9	6.6	Capacitor	F	6201UUC3	6201UUC3
	Drip-proof protected type	0.15	100	2.9	2750	53.2	8.3	Capacitor	E	6200DDU	6200DDU
		0.25	100	4.5	2940	85	33.4	Capacitor	E	6204ZCC3	6203ZCC3
		0.4	100	6.1	2850	51	33.4	Capacitor	E	6204ZCC3	6203ZCC3
3-phase	Totally enclosed self-cooling outdoor type	0.08	200	0.6	2885	486.5	3.4	Direct-on-Line	F	6201UUC3	6201UUC3
	Drip-proof protected type	0.15	200	1	2780	370.5	4.8	Direct-on-Line	E	6200DDU	6200DDU
	Totally enclosed fan-cooled outdoor type	0.25	200	1.2	2910	460	10.5	Direct-on-Line	F	6204ZCC3E	6203ZCC3E
		0.4	200	1.7	2870	379	14.2	Direct-on-Line	F	6204ZCC3E	6203ZCC3E
		0.75	200	3.2	2880	311	26.8	Direct-on-Line	F	6205ZCC3E	6204ZCC3E
		1.5	200	5.9	2895	312	49.3	Direct-on-Line	B	6306ZCC3E	6205ZCC3E
		2.2	200	8.4	2880	400	81.4	Direct-on-Line	B	6306ZCC3E	6205ZCC3E
		3.7	200	14.9	2930	319	143	Direct-on-Line	B	6307ZCC3E	6306ZCC3E
		5.5	200	22	2930	235	182	Direct-on-Line	B	6308ZCC3E	6306ZCC3E
		7.5	200	28.4	2920	242	234	Direct-on-Line	B	6308ZCC3E	6306ZCC3E

* Urea grease is used for the bearing. However, lithium grease is used for 0.15kW.

●Nominal diameter: 125~200mm

Classification		Output kW	Rating			Starting			Thermal class	Bearing	
Phase	Type		Voltage V	Current A	Rotation speed min ⁻¹	Torque %	Current A	Method		Load side (D.S)	Anti-load side (O.S)
3-phase	Totally enclosed fan-cooled outdoor type	7.5	200V	29.0	1465	315	260	Direct-on-Line	F	6308ZCC3	6306ZCC3
		11	200V	43.5	1470	370	366	Direct-on-Line	F	6309ZCC3	6309ZCC3
		15	200V	58.0	1470	364	480	Direct-on-Line	F	6309ZCC3	6309ZCC3
		18.5	200V	69.0	1470	294	576	Direct-on-Line	F	6311ZCC3	6311ZCC3
		22	200V	83.0	1470	325	673	Direct-on-Line	F	6311ZCC3	6311ZCC3
		30	200V	109	1470	295	919	Direct-on-Line	F	6312ZCC3	6311ZCC3
		37	200V	140	1470	343	1211	Direct-on-Line	F	6313ZCC3	6312ZCC3
		45	200V	168	1470	324	1435	Direct-on-Line	F	6313ZCC3	6312ZCC3
		55	200V	202	1475	317	1800	Direct-on-Line	F	6314ZCC3	6313ZCC3
		75	200V	276	1475	263	2401	Direct-on-Line	F	6317ZCC3	6314ZCC3
90	200V	330	1475	255	2720	Direct-on-Line	F	6317ZCC3	6314ZCC3		

* Urea grease is used for bearings.

Component parts list

●Nominal diameter: 25~100mm

Type	Mechanical seal	O-ring (for casing)
LP25A5.04S	EA-104-9	G80
LP25A5.05S	EA-104-9	G80
LP25A5.08S	EH-791-PB-8	G95
LP25A5.15S	EA560-008	G95
LP25A5.25S	H-16	G120
LP32A5.25S	H-16	G120
LP32A5.4S	H-16	G120
LP40A5.25S	H-16	G120
LP40A5.4S	H-16	G120
LP50A5.4S	H-16	G120
LP25A5.08	EH-791-PB-8	G95
LP25A5.15	EA560-008	G95
LP25A5.25-e	H-16	G120
LP32A5.25-e	H-16	G120
LP32A5.4-e	H-16	G120
LP32A5.75-e	H-16	G140
LP40A5.25-e	H-16	G120
LP40A5.4-e	H-16	G120
LP40A5.75-e	H-16	G120
LP40B51.5-e	H-20H	K184
LP40B52.2-e	H-20H	K184
LP50A5.4-e	H-16	G120
LP50A5.75-e	H-16	G120
LP50B51.5-e	H-20H	G140
LP50B52.2-e	H-20H	K184
LP50B53.7-e	H-20H	K184
LP65A5.75-e	H-16	G120
LP65B51.5-e	H-20H	G140
LP65B52.2-e	H-20H	G140
LP65B53.7-e	H-20H	K184
LP65C55.5-e	EA560-25	K198
LP80B51.5-e	H-20H	G140
LP80B52.2-e	H-20H	G140
LP80B53.7-e	H-20H	G140
LP80C55.5-e	EA560-25	K198
LP80C57.5-e	EA560-25	K198
LP100C55.5-e	EA560-25	K198
LP100C57.5-e	EA560-25	K198

●Nominal diameter: 125~200mm

Type	Mechanical seal	O-ring (for Seal cover)
LPE125K-57.5-e	0350/2100/S/AR1S1/BS	G130
LPE125K-511-e	0350/2100/S/AR1S1/BS	G130
LPE125J-515-e	0350/2100/S/AR1S1/BS	G130
LPE125J-518-e	0350/2100/S/AR1S1/BS	G130
LPE125G-522-e	0450/2100/S/AR1S1/BS	K150
LPE125G-530-e	0450/2100/S/AR1S1/BS	K150
LPE150K-511-e	0350/2100/S/AR1S1/BS	G130
LPE150K-515-e	0350/2100/S/AR1S1/BS	G130
LPE150K-518-e	0350/2100/S/AR1S1/BS	G130
LPE150KC-518-e	0350/2100/S/AR1S1/BS	G130
LPE150J-518-e	0450/2100/S/AR1S1/BS	K150
LPE150J-522-e	0450/2100/S/AR1S1/BS	K150
LPE150JC-522-e	0450/2100/S/AR1S1/BS	K150
LPE150J-530-e	0450/2100/S/AR1S1/BS	K150
LPE150G-537-e	0450/2100/S/AR1S1/BS	K150
LPE150GC-537-e	0450/2100/S/AR1S1/BS	K150
LPE150F-545-e	0550/2100/S/AR1S1/BS	K160
LPE150FC-545-e	0550/2100/S/AR1S1/BS	K160
LPE150F-555-e	0550/2100/S/AR1S1/BS	K160
LPE150FC-555-e	0550/2100/S/AR1S1/BS	K160
LPE150F-575-e	0550/2100/S/AR1S1/BS	K160
LPE200K-522-e	0450/2100/S/AR1S1/BS	K150
LPE200K-530-e	0450/2100/S/AR1S1/BS	K150
LPE200J-537-e	0550/2100/S/AR1S1/BS	K160
LPE200JC-537-e	0550/2100/S/AR1S1/BS	K160
LPE200J-545-e	0550/2100/S/AR1S1/BS	K160
LPE200JC-545-e	0550/2100/S/AR1S1/BS	K160
LPE200J-555-e	0550/2100/S/AR1S1/BS	K160
LPE200JC-555-e	0550/2100/S/AR1S1/BS	K160
LPE200J-575-e	0550/2100/S/AR1S1/BS	K160
LPE200JC-575-e	0550/2100/S/AR1S1/BS	K160

Assembly drawing

●LP25A5.04S~5.08S

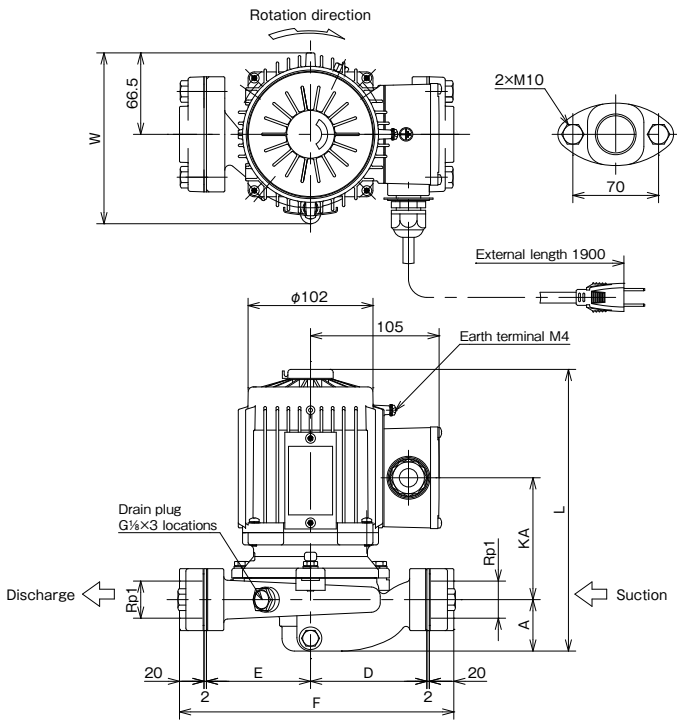

Dimensions

(Unit: mm)

Nominal diameter d	Type	Output kW	Pump and motor						Approx. mass kg	
			A	D	E	F	KA	L		W
25	LP25A5.04S	0.04	30	69	69	182	102	220.5	134.5	6.0
	LP25A5.05S	0.05	30	69	69	182	102	220.5	134.5	6.0
	LP25A5.08S	0.08	42	95	85	224	99.5	230	139.5	8.0

Assembly drawing

●LP25A5.15S

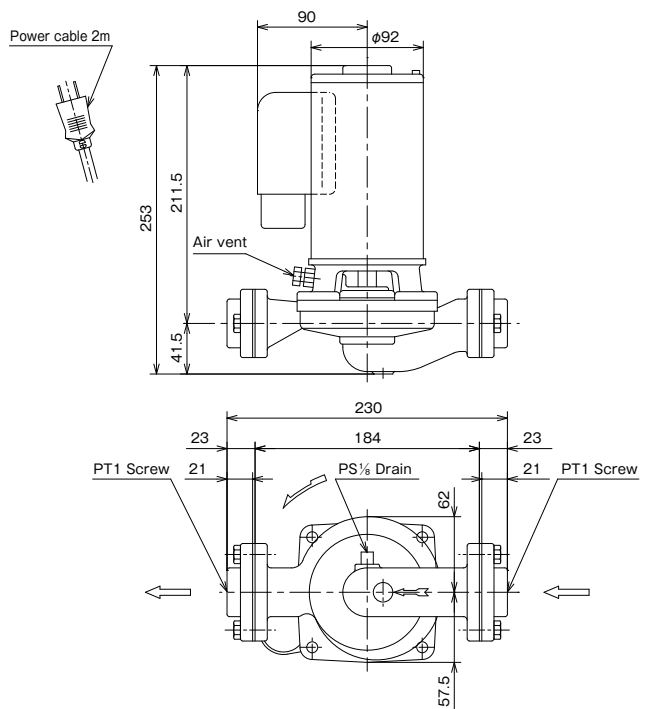

Nominal diameter: 25mm
Phase/voltage: single-phase/100V
Output: 0.15kW
Approx. mass: 7.5kg

Assembly drawing

●LP25A5.08

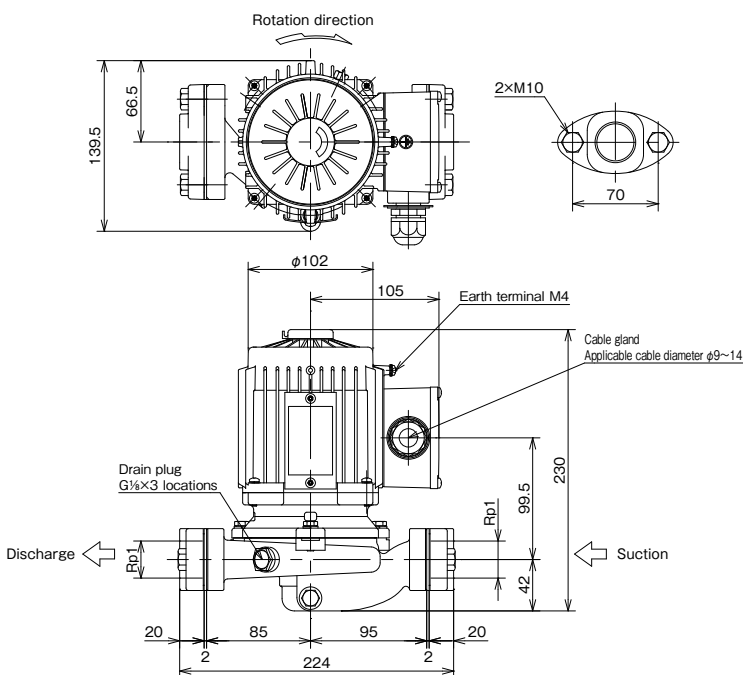

Nominal diameter: 25mm
Phase/voltage: 3-phase/200V
Output: 0.08kW
Approx. mass: 7.0kg

Assembly drawing

●LP25A5.15

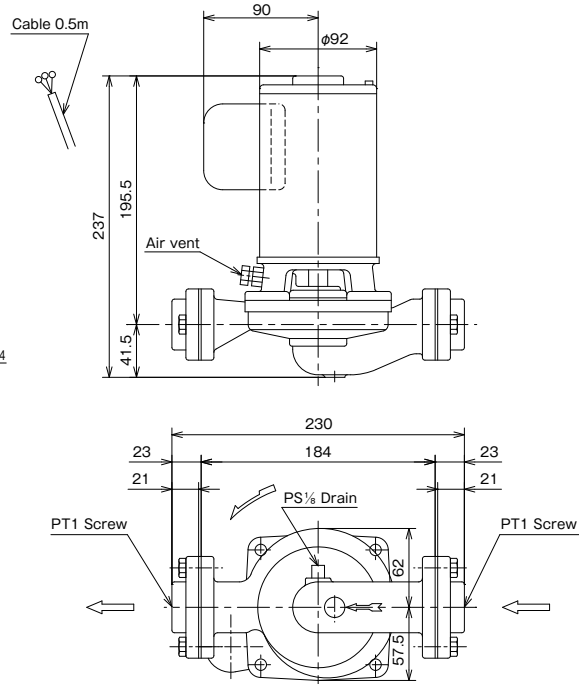

Nominal diameter: 25mm
Phase/voltage: 3-phase/200V
Output: 0.15kW
Approx. mass: 6.4kg

Assembly drawing

●LP25A5.25S

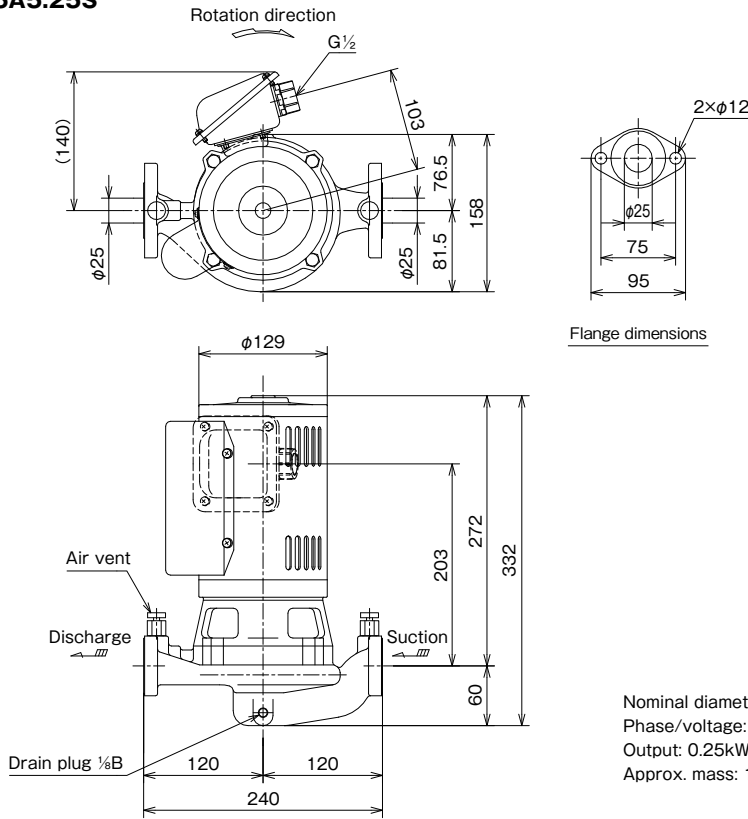

Assembly drawing

●LP32~50A Single phase

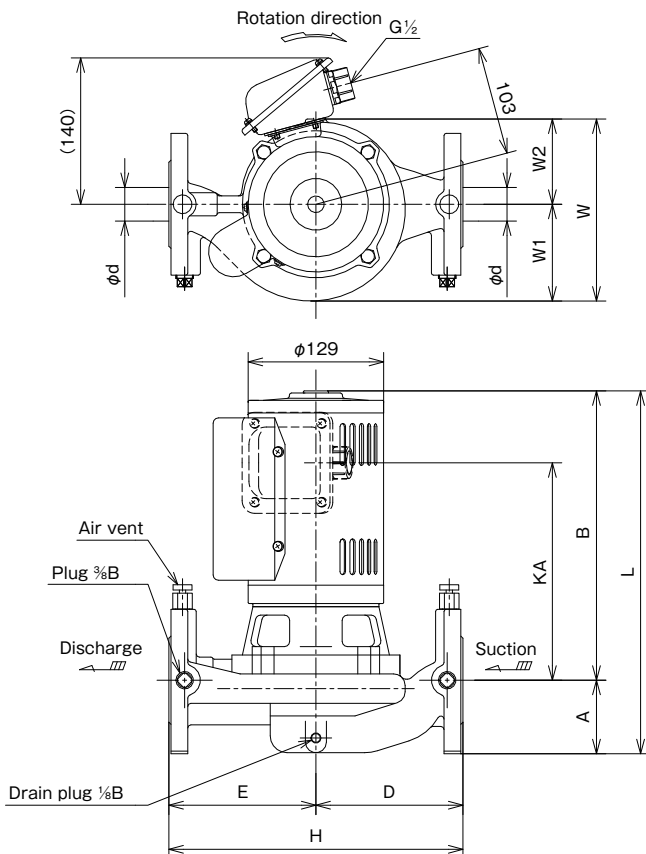

Dimensions

(Unit: mm)

Nominal diameter d	Type	Output kW	A	B	D	E	H
32	LP32A5.25S	0.25	70	276	140	140	280
	LP32A5.4S	0.4	70	276	140	140	280
40	LP40A5.25S	0.25	80	278	150	150	300
	LP40A5.4S	0.4	80	278	150	150	300
50	LP50A5.4S	0.4	85	283	160	150	310

Type	KA	L	W	W1	W2	Approx. mass kg
LP32A5.25S	207	346	173	92	81	28
LP32A5.4S	207	346	173	92	81	27
LP40A5.25S	209	358	171	91	80	30
LP40A5.4S	209	358	171	91	80	29
LP50A5.4S	214	368	178	95	83	31

☆Flange dimensions: JIS 10K thin type or equivalent

Assembly drawing

●LP25A5.25-e

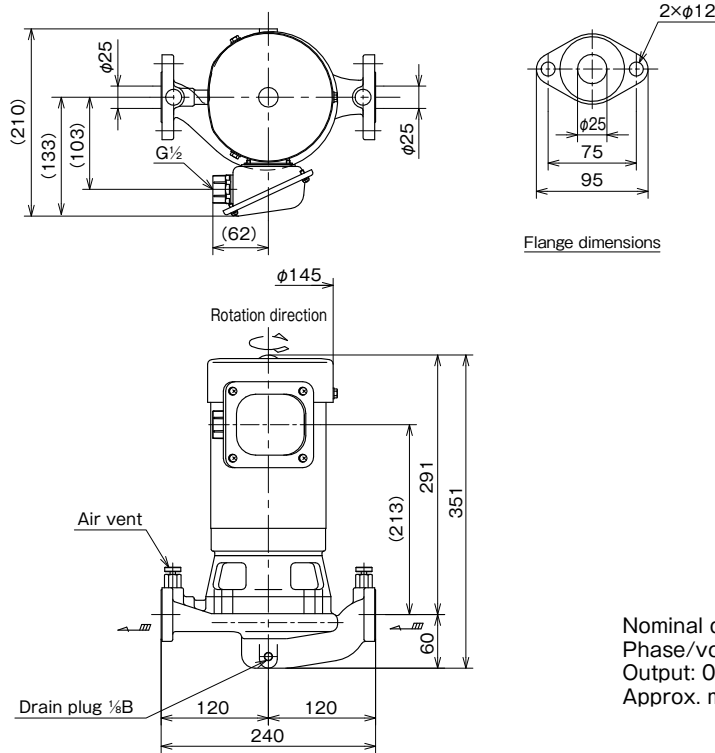

Flange dimensions

Nominal diameter: 25mm
 Phase/voltage: 3-phase/200V
 Output: 0.25kW
 Approx. mass: 18.0kg

Assembly drawing

●LP32~65A-e 0.25~0.75kW

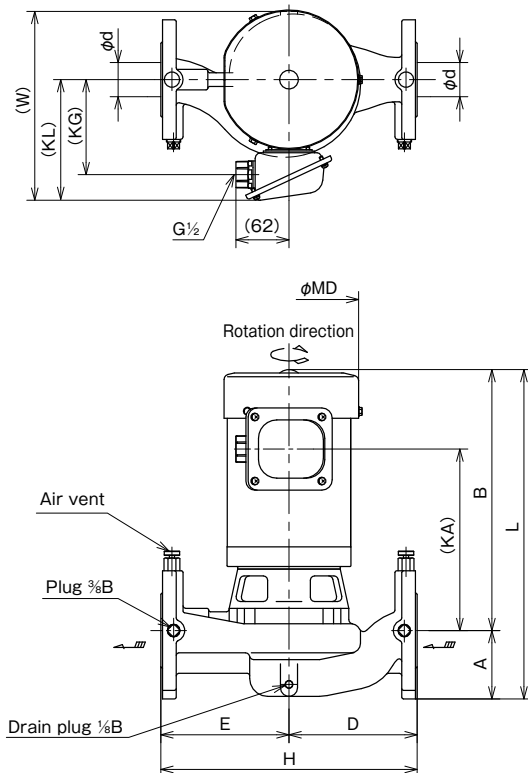

Dimensions

(Unit: mm)

Nominal diameter d	Type	Output kW	A	B	D	E	H
32	LP32A5.25-e	0.25	70	295	140	140	280
	LP32A5.4-e	0.4	70	295	140	140	280
	LP32A5.75-e	0.75	70	304	140	140	280
40	LP40A5.25-e	0.25	80	297	150	150	300
	LP40A5.4-e	0.4	80	297	150	150	300
	LP40A5.75-e	0.75	80	306	150	150	300
50	LP50A5.4-e	0.4	85	302	160	150	310
	LP50A5.75-e	0.75	85	311	160	150	310
65	LP65A5.75-e	0.75	95	318	175	165	340

Type	KA	KG	KL	L	MD	W	Approx. mass kg
LP32A5.25-e	217	103	133	365	145	214	25
LP32A5.4-e	217	103	133	365	145	214	29
LP32A5.75-e	211	111	141	374	163	226	35
LP40A5.25-e	219	103	133	377	145	213	26
LP40A5.4-e	219	103	133	377	145	213	30
LP40A5.75-e	213	111	141	386	163	221	35
LP50A5.4-e	224	103	133	387	145	216	33
LP50A5.75-e	218	111	141	396	163	224	37
LP65A5.75-e	225	111	141	413	163	228	42

☆Flange dimensions: JIS 10K thin type or equivalent

Assembly drawing

●LP-B-e

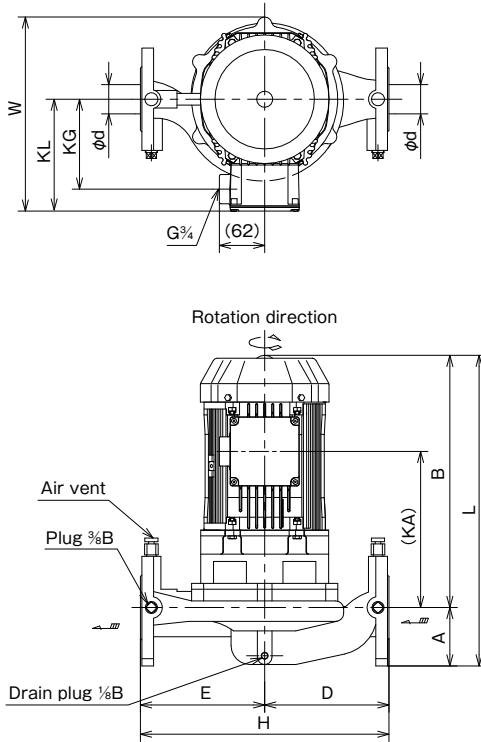

Dimensions

(Unit: mm)

Nominal diameter d	Type	Output kW	A	B	D	E	H
40	LP40B51.5-e	1.5	80	345	170	170	340
	LP40B52.2-e	2.2	80	345	170	170	340
50	LP50B51.5-e	1.5	80	350	155	155	310
	LP50B52.2-e	2.2	80	350	175	165	340
	LP50B53.7-e	3.7	80	393	175	165	340
65	LP65B51.5-e	1.5	95	358	175	165	340
	LP65B52.2-e	2.2	95	358	175	165	340
	LP65B53.7-e	3.7	95	398	175	165	340
80	LP80B51.5-e	1.5	100	360	200	190	390
	LP80B52.2-e	2.2	100	360	200	190	390
	LP80B53.7-e	3.7	100	403	200	190	390

Type	KA	KG	KL	L	W	Approx. mass kg
LP40B51.5-e	214	123	155	425	266	29
LP40B52.2-e	214	123	155	425	266	34
LP50B51.5-e	219	123	155	430	243	31
LP50B52.2-e	219	123	155	430	266	35
LP50B53.7-e	255	147	177	473	289	57
LP65B51.5-e	227	123	155	453	251	35
LP65B52.2-e	227	123	155	453	251	39
LP65B53.7-e	260	147	177	493	289	61
LP80B51.5-e	229	123	155	460	254	47
LP80B52.2-e	229	123	155	460	254	46
LP80B53.7-e	265	147	177	503	278	67

☆Flange dimensions: JIS 10K thin type or equivalent

Assembly drawing

●LP-C-e

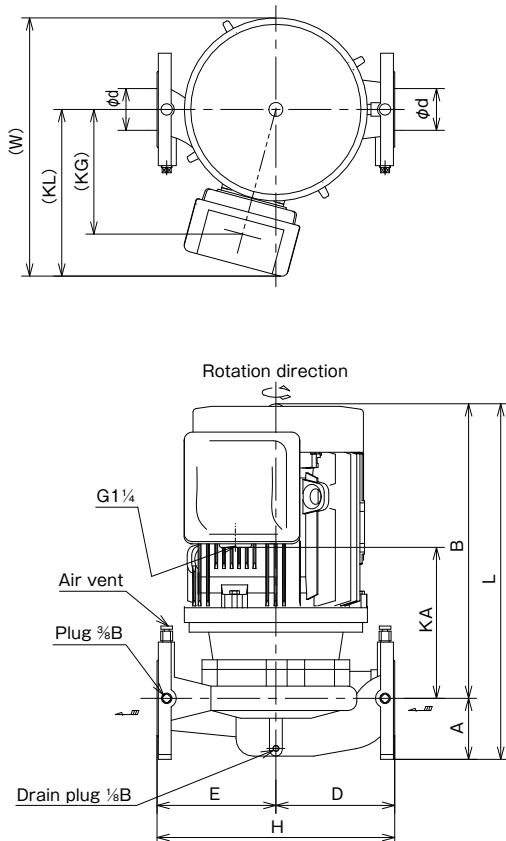

Dimensions

(Unit: mm)

Nominal diameter d	Type	Output kW	A	B	D	E	H
65	LP65C55.5-e	5.5	95	458	185	185	370
80	LP80C55.5-e	5.5	100	461	200	190	390
	LP80C57.5-e	7.5	100	461	200	190	390
100	LP100C55.5-e	5.5	115	460	225	205	430
	LP100C57.5-e	7.5	115	460	225	205	430

Type	KA	KG	KL	L	W	Approx. mass kg
LP65C55.5-e	235	194	260	553	402	81
LP80C55.5-e	238	194	260	561	402	87
LP80C57.5-e	238	194	260	561	402	98
LP100C55.5-e	237	194	260	575	402	94
LP100C57.5-e	237	194	260	575	402	105

☆Flange dimensions: JIS 10K thin type or equivalent

Assembly drawing

●LPE125~200-e

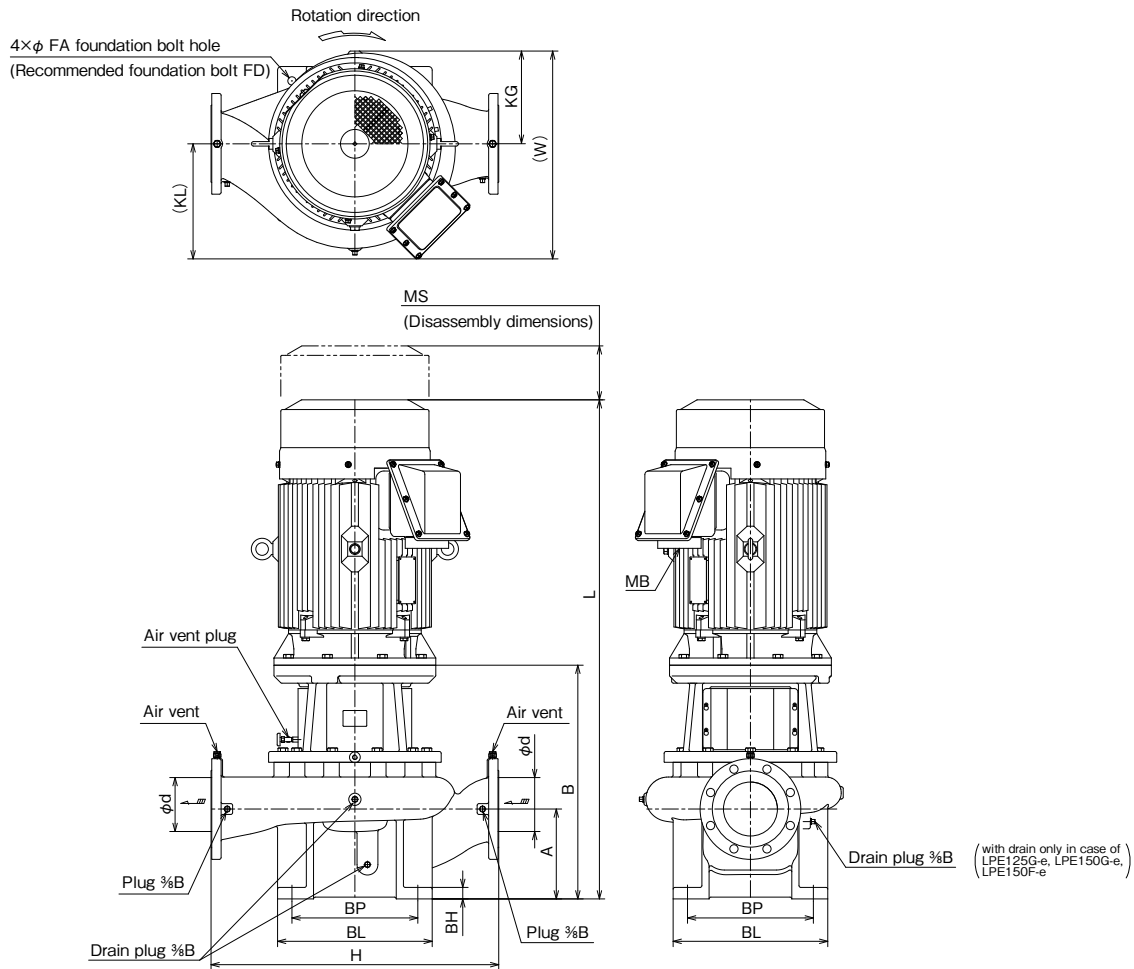

Dimensions

(Unit: mm)

Nominal diameter d	Type	Output kW	A	B	H	KG	KL	L	MB	MS	W	BL	BP	BH	FA	FD	Approx. mass kg
125	LPE125K-57.5-e	7.5	250	608	700	215	256	1067	G1	90	471	360	300	32	23	M20	270
	LPE125K-511-e	11	250	608	700	226	256	1142	G1 1/2	120	482	360	300	32	23	M20	323
	LPE125J-515-e	15	250	608	800	234	276	1172	G1 1/2	120	510	360	300	32	23	M20	358
	LPE125J-518-e	18.5	250	608	800	251	277	1170	G2	120	528	360	300	32	23	M20	406
	LPE125G-522-e	22	250	608	800	254	298	1170	G2	120	552	360	300	32	23	M20	453
	LPE125G-530-e	30	250	608	800	254	306	1210	G2	120	560	360	300	32	23	M20	487
150	LPE150K-511-e	11	250	620	800	231	286	1154	G1 1/2	120	517	430	350	32	23	M20	358
	LPE150K-515-e	15	250	620	800	231	286	1184	G1 1/2	120	517	430	350	32	23	M20	377
	LPE150K(C)-518-e	18.5	250	620	800	251	286	1183	G2	120	537	430	350	32	23	M20	426
	LPE150J-518-e	18.5	250	620	800	260	314	1183	G2	120	574	430	350	32	23	M20	477
	LPE150J(C)-522-e	22	250	620	800	260	314	1183	G2	120	574	430	350	32	23	M20	486
	LPE150J-530-e	30	250	620	800	260	314	1222	G2	120	574	430	350	32	23	M20	520
	LPE150G(C)-537-e	37	250	650	800	258	320	1388	G2 1/2	150	578	430	350	32	23	M20	615
	LPE150F(C)-545-e	45	250	660	1000	311	361	1398	G2 1/2	150	672	500	410	50	25	M22	702
	LPE150F(C)-555-e	55	250	690	1000	311	361	1432	G2 1/2	150	672	500	410	50	25	M22	815
LPE150F-575-e	75	250	690	1000	311	426	1568	G3	150	737	500	410	50	25	M22	982	
200	LPE200K-522-e	22	295	690	900	267	332	1253	G2	120	599	500	410	32	25	M22	467
	LPE200K-530-e	30	295	690	900	267	332	1292	G2	120	599	500	410	32	25	M22	501
	LPE200J(C)-537-e	37	295	730	1000	343	404	1468	G2 1/2	150	747	500	410	50	25	M22	791
	LPE200J(C)-545-e	45	295	730	1000	343	404	1468	G2 1/2	150	747	500	410	50	25	M22	816
	LPE200J(C)-555-e	55	295	760	1000	343	404	1502	G2 1/2	150	747	500	410	50	25	M22	924
	LPE200J(C)-575-e	75	295	760	1000	343	426	1638	G3	150	769	500	410	50	25	M22	1089

Example of sectional drawing

●LP40~50A Single phase

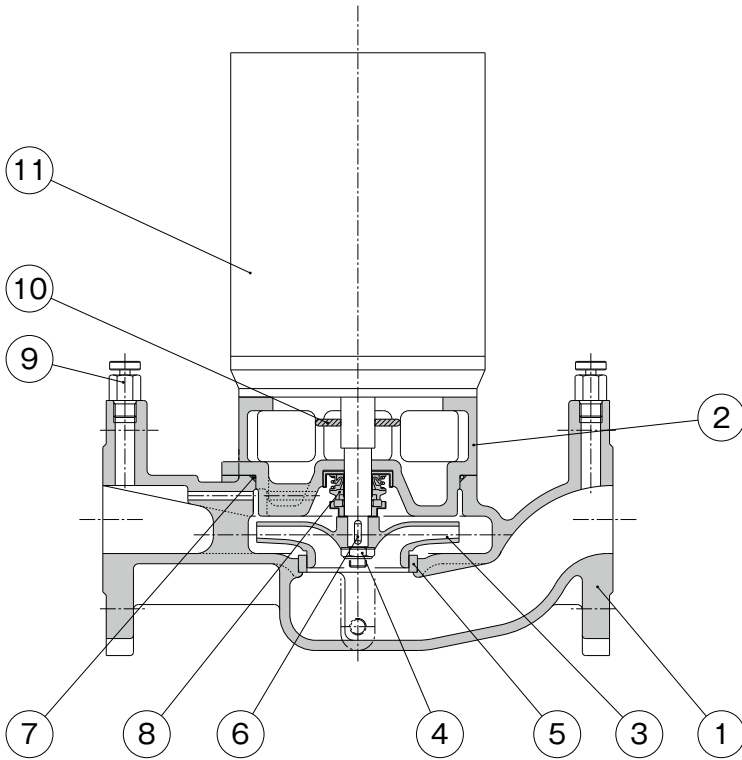

Parts list

No.	Part name	Qty	Material
1	Casing	1	FC200
2	Frame	1	FC200
3	Impeller	1	CAC406
4	Impeller nut	1	SUS304
5	Liner ring	1	CAC406
6	Key	1	SUS420J2
7	O-ring	1	NBR
8	Mechanical seal	1	Ceramic vs Carbon
9	Air vent valve	2	C3604BD
10	Deflector	1	CR
11	Motor	1	

Applicable models: LP40A5.25S / LP40A5.4S / LP50A5.4S

Example of sectional drawing

●LP40~80B-e 1.5kW

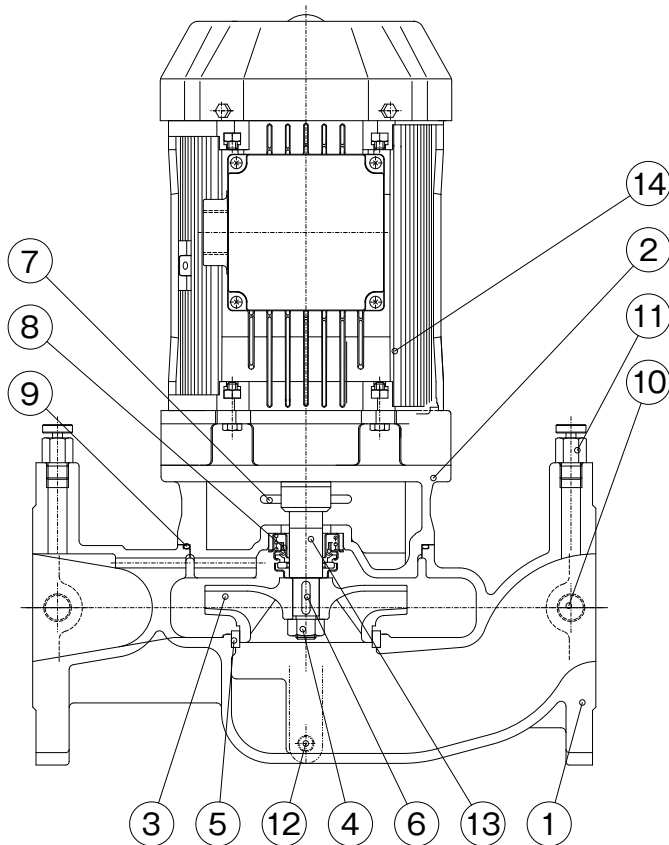

Parts list

No.	Part name	Qty	Material
1	Casing	1	FC200
2	Frame	1	FC200
3	Impeller	1	CAC406
4	Impeller nut	1	SUS304
5	Liner ring	1	CAC406
6	Key	1	SUS304
7	Deflector	1	CR
8	Mechanical seal	1	Ceramic vs Carbon
9	O-ring	1	NBR
10	Plug	2	SWCH
11	Air vent valve	2	C3604BD
12	Drain plug	1	SWCH
13	Motor shaft *1	1	SUS304+S35C
14	Motor	1	-

Applicable models: LP40B-51.5-e / LP50B-51.5-e
LP65B-51.5-e / LP80B-51.5-e

*1 The material is equivalent.

Example of sectional drawing

●LPE-e

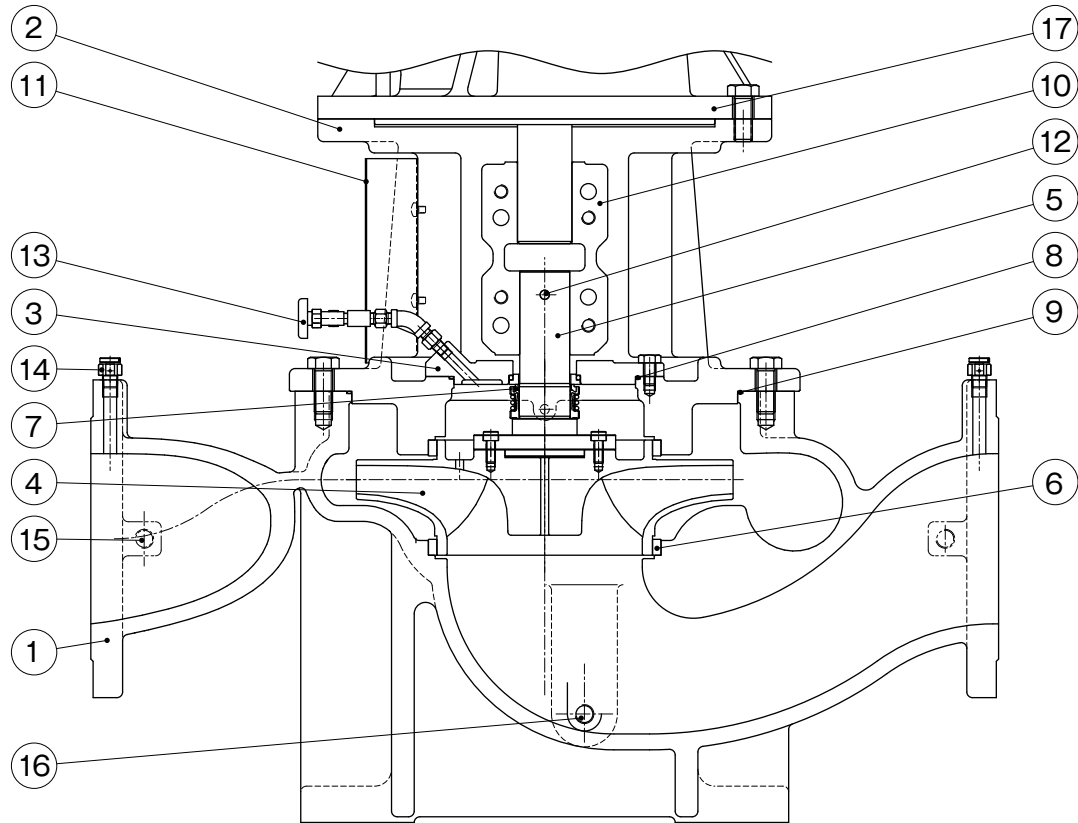

Parts list

No.	Part name	Qty	Material
1	Casing	1	FCD450
2	Frame	1	FCD450
3	Seal cover	1	FCD450
4	Impeller	1	SCS13
5	Main shaft	1	SUS420J2
6	Liner ring	2	CAC406
7	Mechanical seal	1	SiC vs Carbon
8	O-ring	1	NBR
9	O-ring	1	NBR

No.	Part name	Qty	Material
10	Coupling	1	FCD450
11	Coupling cover	2	SUS304
12	Parallel pin	1	S45C
13	Air vent valve	1	C3771B
14	Air vent plug	2	C3604BD
15	Plug	2	SWCH
16	Drain plug	2*	SWCH
17	Motor	1	—

Applicable models: LPE125-e / LPE150-e / LPE200-e
 * 3 drain plugs for LPE125G-e, LPE150G-e and LPE150F-e.

Installation method

●Nominal diameter: 25~100mm

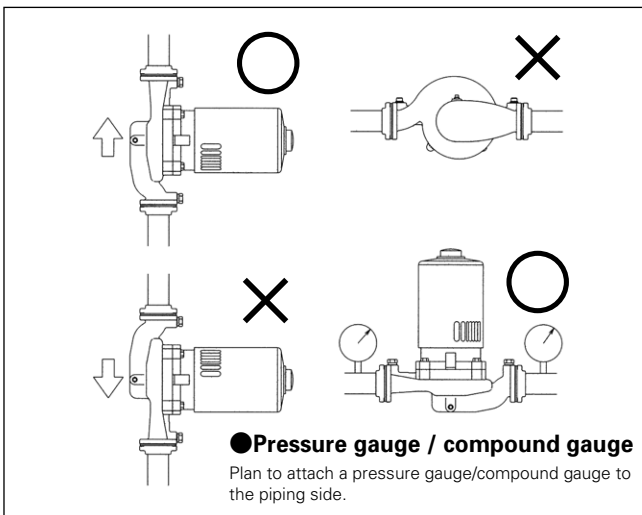

●Nominal diameter: 125~200mm

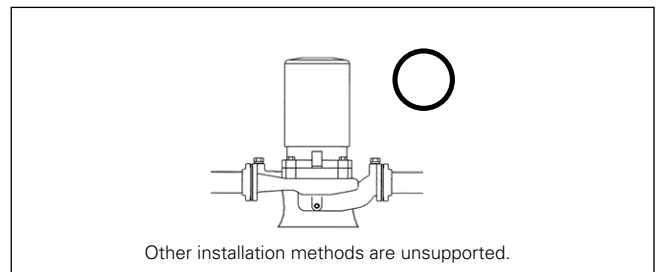



TERAL INC.

Head Office 230, Moriwake, Miyuki-cyo, Fukuyama-city, Hiroshima, 720-0003, Japan
Tel.+81-84-955-1111 Fax.+81-84-955-5777
www.teral.net

Teral Asia Limited

Room 1001,10/F, Olympia Plaza, 255 King's Road, North Point, Hong Kong
Tel.+852-2571-0935 Fax.+852-2571-0619

TERAL THAI CO.,LTD.

150 Moo 16 Udomsorayuth Rd., T.Bangkrasan, A.Bangpa-In, Ayutthaya 13160 Thailand
Tel.+66-3535-2148-9 Fax.+66-3535-2150

TERAL TRADING & SERVICE CO.,LTD.

150 Moo 16 Udomsorayuth Rd., T.Bangkrasan, A.Bangpa-In, Ayutthaya 13160 Thailand
Tel.+66-3535-2145-7 Fax.+66-3535-8549

Teral Malaysia Sdn.Bhd.

10, Jalan SS13/6A, Subang Jaya Industrial Estate, 47500, Subang Jaya, Selangor D.E, Malaysia
Tel.+60-3-5611 5775 Fax.+60-3-5612 5775

PT.Teral Indonesia Pumps and Fans

Komplek Pergudangan Taman Tekno Blok M No.26.Jl.BSD Sektor XI, Kelurahan Setu,
Kecamatan Setu, Kota Tangerang Selatan, Provinsi Banten.15314.
Tel.+62-21-29665778 Fax.+62-21-75673913

Teral Vietnam Limited Liability Company

9th Floor, LADECO Building, No. 266 Doi Can Street, Lieu Giai Ward, Ba Dinh District, Hanoi City, Vietnam
Tel.+84-24-393-52-790 Fax.+84-24-393-52-289

Teral General Machine (Shanghai) Co.,Ltd.

No.285, Yuan Qu Road(N), Bei Qiao, Min Hang District, Shanghai 201109, China
Tel.+86-21-6490-9128 Fax.+86-21-6490-9126

Teral-Aerotech Fans Private Ltd.

Plot No.188-189, Ecotech Extension-1, Surajpur Kasna Road, Greater Noida-201306, Uttar Pradesh, India
Tel.+91-9810162210, +91-9310162210

Teral Middle East F.Z.C.

1806-002, 18th floor, BB1, Mazaya Business Avenue, JLT, Dubai, UAE. PO Box 414781
Tel.+971-4369 9039

Teral Pumps & Fans North America Ltd.

Suite # 197, 800-15355 24 Ave Surrey, B.C., CANADA V4A 2H9
Tel.+1-604-839-1008

Teral Philippines Inc.

Roof Deck 3, Vernida 1 Building, 120 Amorsolo St., Legaspi Village, Makati City
Tel.+63 2 7717-9314

Please note that product specifications are subject to change for improvement without prior notice.