

Volute pumps

SJ

TERAL



Triple e series

50Hz



TERAL INC.

Applications

- General water supply in buildings and apartments, etc
- Hot and cold water circulation
- Supply of industrial water
- Conveyance and distribution of tap water
- Water sprinkling and irrigation of paddies and fields

Features

- ① Energy-saving pump with a Top Runner efficiency (equivalent to IE3) motor.
- ② Compact and lightweight by adoption of a 2-pole motor.
- ③ Easy installation in a small space.
- ④ B.P.O.(back pull-out) structure for easy disassembly and maintenance.
- ⑤ Robust structure for piping load with stable installation because of upright discharge.

Description of types

SJ 32 × 32 M 5 1.5 - H - e

- ① Model
- ② Nominal suction diameter (32mm)
- ③ Nominal discharge diameter (32mm)
- ④ Frequency (50Hz)
- ⑤ Output (1.5kW)
- ⑥ Performance code None : Standard
H : According to customer specified point
- ⑦ Equipped with a Top Runner motor (equivalent to IE3)

Standard specifications

Pumping liquid	Liquid quality	Fresh water
	Liquid temperature	0 - 80°C
Total suction head (In case of 20°C)		-6m; -5m for 100×80
Allowable boost pressure		See the Specification table.
Structure	Impeller	Closed
	Shaft seal	Mechanical seal (SiC vs Carbon)
	Bearing	Sealed ball bearing
Material	Impeller	CAC406 (65×50M, 80×65M...FC200)
	Shaft	SUS403
	Casing	FC200 or FCD450*1
Motor	Efficiency	Top Runner efficiency (equivalent to IE3)
	Starting method	Direct-on-Line start : 7.5kW or less Star-delta start : 11kW or more
	Type	Totally enclosed fan-cooled outdoor type : 0.75kW Totally enclosed fan-cooled indoor type : 1.5kW or more
	Power source	3-phase, 200V
	Synchronous rotation speed	3000min ⁻¹
Flange spec		JIS 10K standard type
Paint color		7.5BG5/1.5

*1 The material differs according to the type.

Standard accessories

Motor	1
Common base	1
Priming plug	1
Coupling	1 set
Coupling cover	1



* Please note that some of the devices in the photo may differ from actual devices in coating color, etc.

Special specifications

Structure	Shaft seal	Mechanical seal (SiC vs SiC) Grand packing External water feeding ... In the case where foreign substances are contained in the liquid handled
	Other	Drain (below gland/below casing) Sealed coupling cover, No common base
Material	Impeller	CAC406 (65×50M, 80×65M)
	Shaft	SUS304
Motor	Type	All steel made
	Power supply	Totally enclosed fan-cooled outdoor type (1.5kW or more) Voltage change
Paint	Specified color for outer surface, salt-resistant paint, heavy-duty salt-resistant paint Japan Sewage Works Agency specifications	

* Please note that in case of special specifications, the assembly drawing, etc., may differ from the standard drawing.

Special accessories

- Foot valve
- Suction cover
- Sluice valve, Check valve Bolt, nut, and packing included
- Companion flange Bolt, nut, and packing included
- Special companion flange (when adjusting the discharge diameter to the suction diameter) Bolt and nut included
- Tube with different diameter See the figure below
- Vibration isolator
- Pressure gauge, vacuum gauge, compound gauge Cock and pipe included
- Vibration isolation joint

Foot valve, pipe reducer, special companion flange application table

Nominal diameter mm	Foot valve nominal diameter mm		Pipe reducer	Special companion flange
	Suction	Discharge		
32	32	32	—	—
40	40	40	—	—
50	40	50	—	40/50
65	50	65	—	50/65
80	65	100	80×100	65/80
100	80	125	100×125	80/100

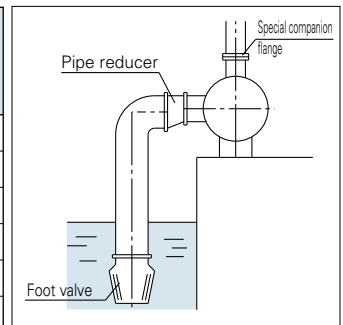

* Special companion flange is used to adjust the discharge diameter to the suction diameter.

Selection chart

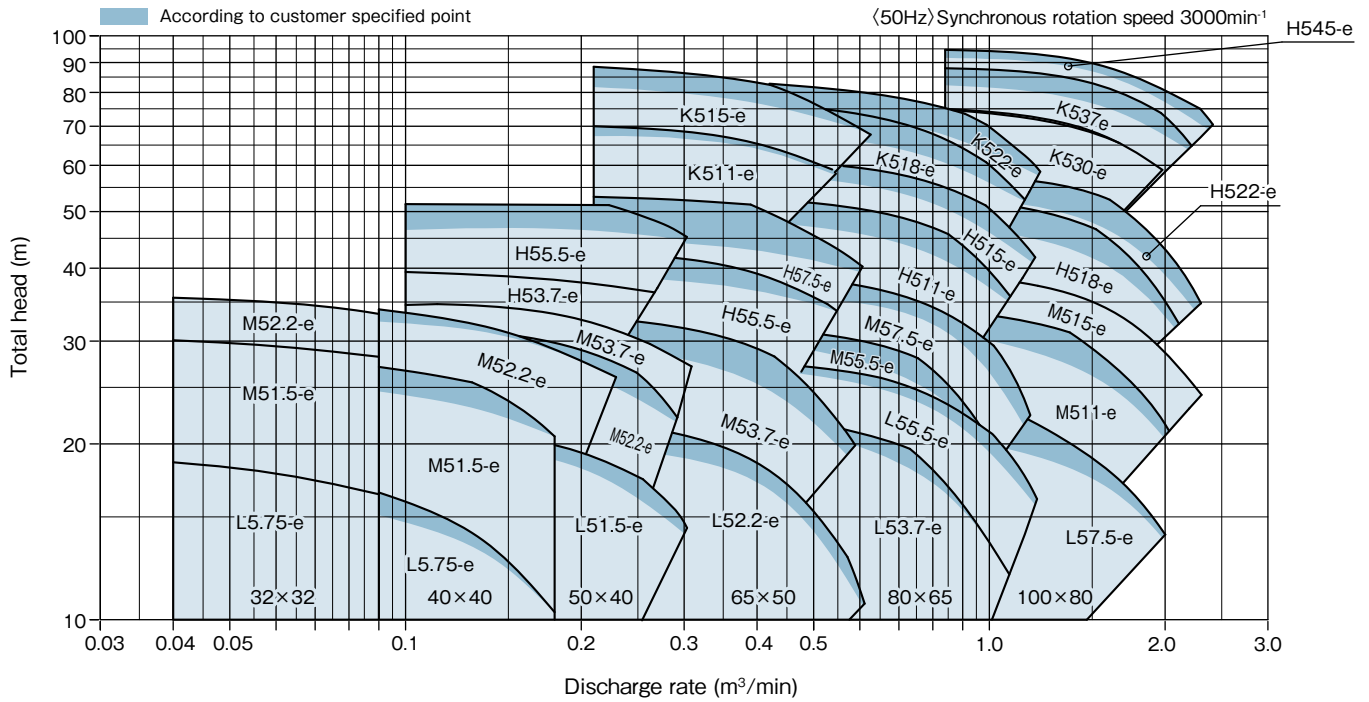

Specification table

Nominal diameter mm		Type	Output kW	Specifications		
Suction	Discharge			Discharge rate m³/min	Total head m	Allowable boost pressure MPa
32	32	SJ32×32L5.75-e	0.75	0.06	17.8	0.80
		SJ32×32M51.5-e	1.5	0.06	29.4	0.69
		SJ32×32M52.2-e	2.2	0.09	33.4	0.63
40	40	SJ40×40L5.75-e	0.75	0.14	12.8	0.82
		SJ40×40L5.75H-e	0.75	—	—	—
		SJ40×40M51.5-e	1.5	0.14	22.6	0.73
		SJ40×40M51.5H-e	1.5	—	—	—
		SJ40×40M52.2-e	2.2	0.15	30.5	0.66
		SJ40×40M52.2H-e	2.2	—	—	—
		SJ40×40M52.2H-e	2.2	—	—	—
50	40	SJ50×40L51.5-e	1.5	0.21	17.8	0.79
		SJ50×40L51.5H-e	1.5	—	—	—
		SJ50×40M52.2-e	2.2	0.21	25.9	0.70
		SJ50×40M52.2H-e	2.2	—	—	—
		SJ50×40M53.7-e	3.7	0.21	32.2	0.64
		SJ50×40H53.7-e	3.7	0.21	37.6	0.60
		SJ50×40H55.5-e	5.5	0.21	46.4	0.52
		SJ50×40H55.5H-e	5.5	—	—	—
		SJ50×40H55.5H-e	5.5	—	—	—
65	50	SJ65×50L52.2-e	2.2	0.42	16.7	0.79
		SJ65×50L52.2H-e	2.2	—	—	—
		SJ65×50M53.7-e	3.7	0.42	24.7	0.69
		SJ65×50M53.7H-e	3.7	—	—	—
		SJ65×50H55.5-e	5.5	0.42	36.3	0.61
		SJ65×50H55.5H-e	5.5	—	—	—
		SJ65×50H57.5-e	7.5	0.42	42.6	0.55
		SJ65×50H57.5H-e	7.5	—	—	—
		SJ65×50K511-e	11	0.42	63.3	0.30
		SJ65×50K511H-e	11	—	—	—
		SJ65×50K515-e	15	0.42	76.0	0.16
		SJ65×50K515H-e	15	—	—	—

Nominal diameter mm		Type	Output kW	Specifications				
Suction	Discharge			Discharge rate m³/min	Total head m	Allowable boost pressure MPa		
80	65	SJ80×65L53.7-e	3.7	0.84	16.5	0.77		
		SJ80×65L53.7H-e	3.7	—	—	—		
		SJ80×65L55.5-e	5.5	0.84	22.3	0.72		
		SJ80×65L55.5H-e	5.5	—	—	—		
		SJ80×65M55.5-e	5.5	0.84	23.6	0.70		
		SJ80×65M55.5H-e	5.5	—	—	—		
		SJ80×65M57.5-e	7.5	0.84	31.2	0.63		
		SJ80×65M57.5H-e	7.5	—	—	—		
		SJ80×65H511-e	11	0.84	41.2	0.51		
		SJ80×65H511H-e	11	—	—	—		
		SJ80×65H515-e	15	0.84	50.6	0.41		
		SJ80×65H515H-e	15	—	—	—		
		SJ80×65K518-e	18.5	0.84	60.7	0.31		
		SJ80×65K518H-e	18.5	—	—	—		
		SJ80×65K522-e	22	0.84	67.6	0.23		
		SJ80×65K522H-e	22	—	—	—		
		100	80	SJ100×80L57.5-e	7.5	1.67	16.3	0.79
				SJ100×80L57.5H-e	7.5	—	—	—
				SJ100×80M511-e	11	1.67	24.4	0.70
				SJ100×80M511H-e	11	—	—	—
SJ100×80M515-e	15			1.67	33.2	0.62		
SJ100×80H518-e	18.5			1.67	39.2	0.54		
SJ100×80H518H-e	18.5			—	—	—		
SJ100×80H522-e	22			1.67	45.4	0.48		
SJ100×80H522H-e	22			—	—	—		
SJ100×80K530-e	30			1.67	65.5	0.26		
SJ100×80K530H-e	30			—	—	—		
SJ100×80K537-e	37			1.67	73.9	0.19		
SJ100×80K537H-e	37			—	—	—		
SJ100×80K545-e	45	1.67	84.0	0.09				
SJ100×80K545H-e	45	—	—	—				

Assembly drawing

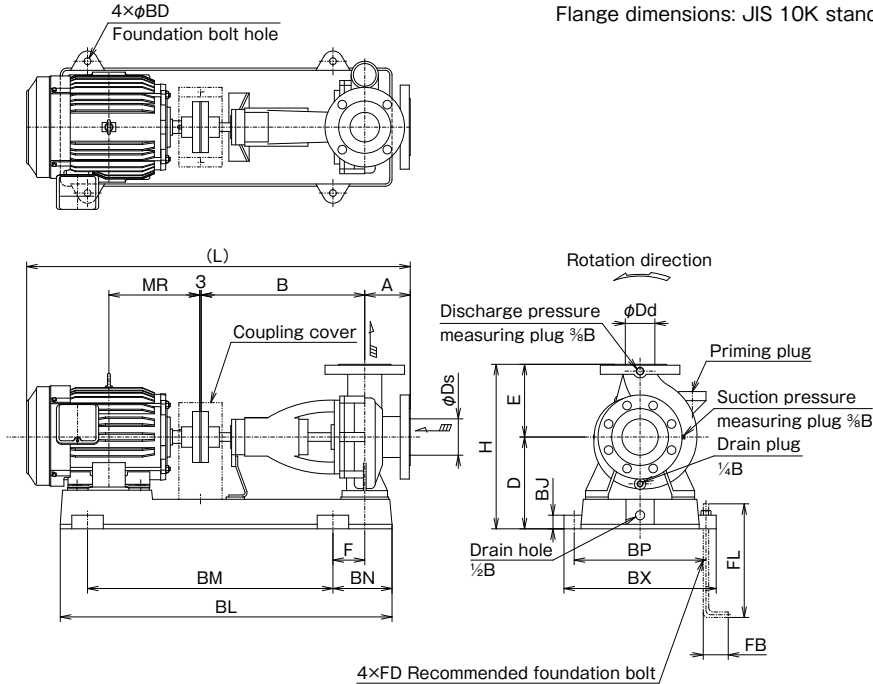

Flange dimensions: JIS 10K standard type or equivalent

Note) Overall length dimensions, approximate mass and terminal box position may vary depending on the motor manufacturer.

Dimensions

(Unit: mm)

Nominal diameter	Suction Ds	Discharge Dd	Type	Output kW	Pump / Motor							Common base							Foundation bolt			Approx. mass kg	
					A	B	D	E	F	H	L	MR	BD	BJ	BL	BM	BN	BP	BX	FB	FD		FL
32	32		SJ32×32L5.75-e	0.75	75	360	162	120	55	282	700	140	13	25	650	445	115	230	265	45	M10	200	56
			SJ32×32M51.5-e	1.5	75	360	182	160	55	342	750	169	13	25	685	480	115	290	325	45	M10	200	76
			SJ32×32M52.2-e	2.2	75	360	182	160	55	342	750	169	13	25	685	480	115	290	325	45	M10	200	78
40	40		SJ40×40L5.75(H)-e	0.75	75	360	162	120	55	282	700	140	13	25	650	445	115	230	265	45	M10	200	57
			SJ40×40M51.5(H)-e	1.5	75	360	182	160	55	342	750	169	13	25	685	480	115	290	325	45	M10	200	77
			SJ40×40M52.2(H)-e	2.2	75	360	182	160	55	342	750	169	13	25	685	480	115	290	325	45	M10	200	79
50	40		SJ50×40L51.5(H)-e	1.5	80	360	162	140	55	302	755	169	13	25	685	480	115	230	265	45	M10	200	74
			SJ50×40M52.2(H)-e	2.2	80	360	182	160	55	342	755	169	13	25	685	480	115	290	325	45	M10	200	84
			SJ50×40M53.7-e	3.7	80	360	202	160	70	362	824	200	15	30	730	540	130	290	335	55	M12	250	100
			SJ50×40H53.7-e	3.7	80	360	230	180	70	410	824	200	15	30	730	540	130	290	335	55	M12	250	107
			SJ50×40H55.5(H)-e	5.5	80	360	230	180	55	410	894	239	15	30	820	540	130	350	395	55	M12	250	139
65	50		SJ65×50L52.2(H)-e	2.2	80	360	162	140	55	302	755	169	13	25	685	480	115	260	295	45	M10	200	77
			SJ65×50M53.7(H)-e	3.7	80	360	202	160	70	362	824	200	15	30	730	540	130	290	335	55	M12	250	104
			SJ65×50H55.5(H)-e	5.5	100	360	230	180	55	410	914	239	15	30	820	540	130	350	395	55	M12	250	153
			SJ65×50H57.5(H)-e	7.5	100	360	230	180	55	410	914	239	15	30	820	540	130	350	395	55	M12	250	159
			SJ65×50K511(H)-e	11	100	360	265	225	95	490	1107	323	20	40	950	660	170	400	456	70	M16	315	254
80	65		SJ80×65L53.7(H)-e	3.7	100	360	202	160	70	362	844	200	15	30	730	540	130	290	335	55	M12	250	112
			SJ80×65L55.5(H)-e	5.5	100	360	202	160	70	362	914	239	15	30	820	540	130	320	365	55	M12	250	139
			SJ80×65M55.5(H)-e	5.5	100	360	230	180	55	410	914	239	15	30	820	540	130	350	395	55	M12	250	148
			SJ80×65M57.5(H)-e	7.5	100	360	230	180	55	410	914	239	15	30	820	540	130	350	395	55	M12	250	154
			SJ80×65H511(H)-e	11	100	360	245	200	95	445	1107	323	20	40	950	660	170	400	456	70	M16	315	241
			SJ80×65H515(H)-e	15	100	360	245	200	95	445	1107	323	20	40	950	660	170	400	456	70	M16	315	242
			SJ80×65K518(H)-e	18.5	100	360	265	225	95	490	1137	345	20	40	950	660	170	400	456	70	M16	315	285
			SJ80×65K522(H)-e	22	100	360	265	225	95	490	1136	352	20	40	1000	660	170	440	496	70	M16	315	343
100	80		SJ100×80L57.5(H)-e	7.5	100	360	230	180	55	410	914	239	15	30	820	540	130	350	395	55	M12	250	162
			SJ100×80M511(H)-e	11	100	360	245	200	95	445	1107	323	20	40	950	660	170	400	456	70	M16	315	249
			SJ100×80M515-e	15	100	360	245	200	95	445	1107	323	20	40	950	660	170	400	456	70	M16	315	262
			SJ100×80H518(H)-e	18.5	100	360	265	225	95	490	1137	345	20	40	950	660	170	400	456	70	M16	315	297
			SJ100×80H522(H)-e	22	100	360	265	225	95	490	1136	352	20	40	1000	660	170	440	496	70	M16	315	356
			SJ100×80K530(H)-e	30	100	470	290	250	100	540	1284	371	25	50	1120	740	190	440	510	90	M20	400	409

*Mounting dimensions are compatible with SJ model (product equipped with totally enclosed fan-cooled IE1 motor). Also the motor frame number is the same. Therefore, replacement with a Top Runner efficiency (equivalent to IE3) motor is possible. However, please keep the following point in mind. The number of revolutions will increase because of the characteristics of the motor, which may cause the flow rate to exceed the rated current value. Please adjust the flow rate to use the motor within the rated current value.

*For products equipped with a drip-proof protection type motor, there are some types which also require a common base because the frame No. may be different when only the motor is replaced.

Assembly drawing

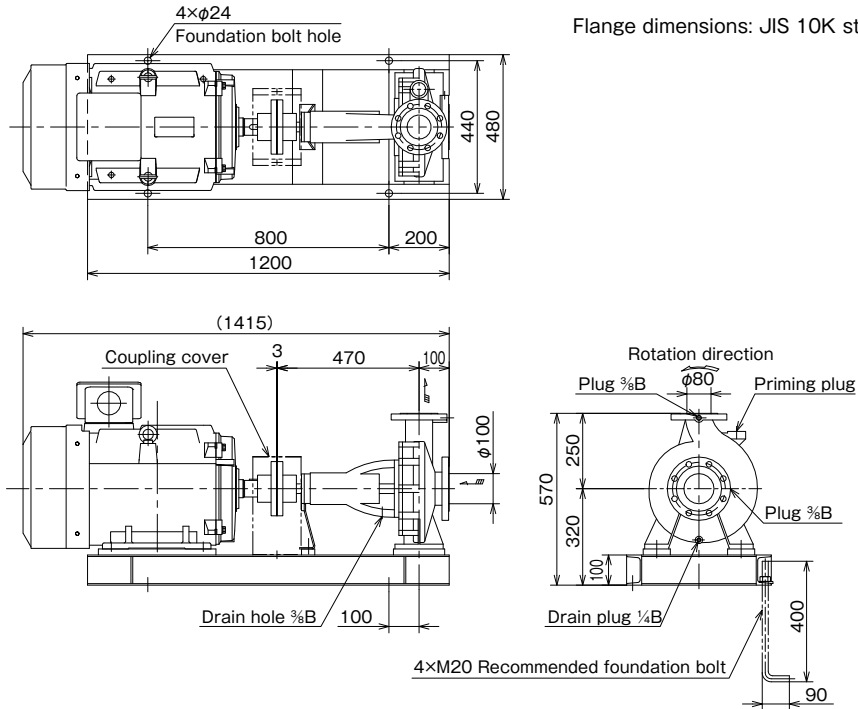

Flange dimensions: JIS 10K standard type or equivalent

Note) Overall length dimensions, approximate mass and terminal box position may vary depending on the motor manufacturer.

Dimensions

(Unit: mm)

Type	Output kW	Approx. mass kg
SJ100×80K537(H)-e	37	402
SJ100×80K545(H)-e	45	488

*Mounting dimensions are compatible with SJ model (product equipped with totally enclosed fan-cooled IE1 motor). Also the motor frame number is the same. Therefore, replacement with a Top Runner efficiency (equivalent to IE3) motor is possible. However, please keep the following point in mind. The number of revolutions will increase because of the characteristics of the motor, which may cause the flow rate to exceed the rated current value. Please adjust the flow rate to use the motor within the rated current value.

*For products equipped with a drip-proof protection type motor, there are some types which also require a common base because the frame No. may be different when only the motor is replaced.

Example of sectional drawing

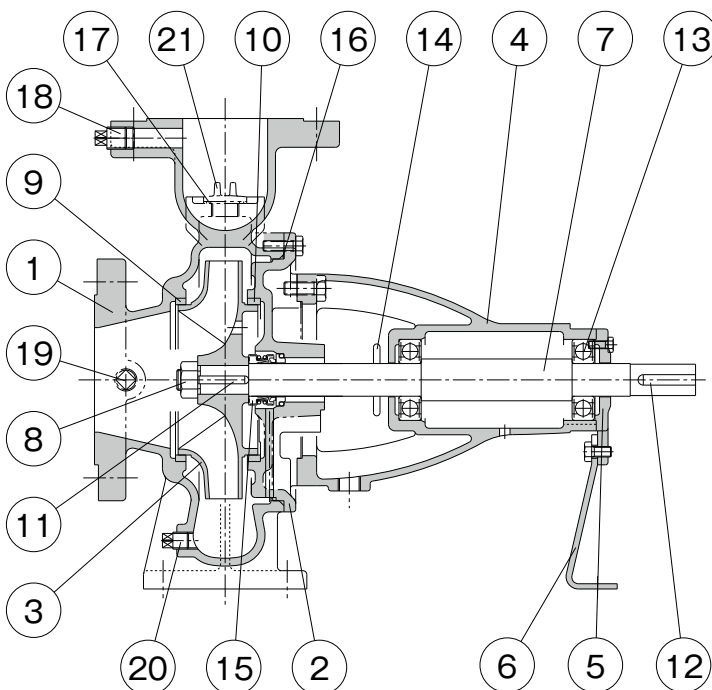

Parts list

No.	Part name	Qty	Material
1	Casing	1	FC200/FCD450
2	Casing cover	1	FC200
3	Impeller	1	CAC406/FC200
4	Bearing case	1	FC200
5	Bearing cover	1	FC200
6	Mounting leg	1	SS400
7	Main shaft	1	SUS403
8	Impeller nut	1	SUS304
9	Liner ring	1	CAC406
10	Liner ring	1	CAC406
11	Impeller key	1	SUS304
12	Coupling key	1	S45C
13	Ball bearing	2	SUJ2
14	Deflector	1	CR
15	Mechanical seal	1	SiC vs Carbon
16	O-ring	1	NBR
17	O-ring	1	NBR
18	Plug	1	SWCH
19	Plug	1	SWCH
20	Drain plug	1	SWCH
21	Priming plug	1	C3771B

Note) This is a representative example. For details, see the sectional drawing of each model.



TERAL INC.

Head Office 230, Moriwake, Miyuki-cyo, Fukuyama-city, Hiroshima, 720-0003, Japan
Tel.+81-84-955-1111 Fax.+81-84-955-5777
www.teral.net

Teral Asia Limited

Room 1001,10/F, Olympia Plaza, 255 King's Road, North Point, Hong Kong
Tel.+852-2571-0935 Fax.+852-2571-0619

TERAL THAI CO.,LTD.

150 Moo 16 Udomsorayuth Rd., T.Bangkrasan, A.Bangpa-In, Ayutthaya 13160 Thailand
Tel.+66-3535-2148-9 Fax.+66-3535-2150

TERAL TRADING & SERVICE CO.,LTD.

150 Moo 16 Udomsorayuth Rd., T.Bangkrasan, A.Bangpa-In, Ayutthaya 13160 Thailand
Tel.+66-3535-2145-7 Fax.+66-3535-8549

Teral Malaysia Sdn.Bhd.

10, Jalan SS13/6A, Subang Jaya Industrial Estate, 47500, Subang Jaya, Selangor D.E, Malaysia
Tel.+60-3-5611 5775 Fax.+60-3-5612 5775

PT.Teral Indonesia Pumps and Fans

Komplek Pergudangan Taman Tekno Blok M No.26.Jl.BSD Sektor XI, Kelurahan Setu,
Kecamatan Setu, Kota Tangerang Selatan, Provinsi Banten.15314.
Tel.+62-21-29665778 Fax.+62-21-75673913

Teral Vietnam Limited Liability Company

9th Floor, LADECO Building, No. 266 Doi Can Street, Lieu Giai Ward, Ba Dinh District, Hanoi City, Vietnam
Tel.+84-24-393-52-790 Fax.+84-24-393-52-289

Teral General Machine (Shanghai) Co.,Ltd.

No.285, Yuan Qu Road(N), Bei Qiao, Min Hang District, Shanghai 201109, China
Tel.+86-21-6490-9128 Fax.+86-21-6490-9126

Teral-Aerotech Fans Private Ltd.

Plot No.188-189, Ecotech Extension-1, Surajpur Kasna Road, Greater Noida-201306, Uttar Pradesh, India
Tel.+91-9810162210, +91-9310162210

Teral Middle East F.Z.C.

1806-002, 18th floor, BB1, Mazaya Business Avenue, JLT, Dubai, UAE. PO Box 414781
Tel.+971-4369 9039

Teral Pumps & Fans North America Ltd.

Suite # 197, 800-15355 24 Ave Surrey, B.C., CANADA V4A 2H9
Tel.+1-604-839-1008

Teral Philippines Inc.

Roof Deck 3, Vernida 1 Building, 120 Amorsolo St., Legaspi Village, Makati City
Tel.+63 2 7717-9314

Please note that product specifications are subject to change for improvement without prior notice.

2023 , 07